



ELECTRIC ENERGY PROCESSING SYSTEMS: DYNAMIC MODELING AND CONTROL

August 2009

Alex M. Stanković

Northeastern University, Boston

astankov@ece.neu.edu

90% of U.S. Electricity Today



Environmental Effects



Presentation Map

- Energy Systems - Past & Present,
- A Personal Interlude - Dynamic Phasors,
- Energy Systems - Future.

Why Energy Systems?

Systems aim to achieve level of **reliability** that far exceeds the reliability of individual components, through control actions based on **evaluating or sensing** its current state.

Why Energy Systems?

Systems aim to achieve level of **reliability** that far exceeds the reliability of individual components, through control actions based on **evaluating or sensing** its current state.

Examples of energy system reliability targets:

Reliability %	N "nines"	Down time
99.9	3	9 hr/yr
99.999	5	5 min/yr
99.99999	7	3 sec/yr
99.9999999	9	2 cycles/yr

Why Energy Systems?

Systems aim to achieve level of **reliability** that far exceeds the reliability of individual components, through control actions based on **evaluating or sensing** its current state.

Examples of energy system reliability targets:

Reliability %	N "nines"	Down time
99.9	3	9 hr/yr
99.999	5	5 min/yr
99.99999	7	3 sec/yr
99.9999999	9	2 cycles/yr

Events from real life (G.T. Heydt):

Losing in roulette	N=1.6
Losing the PowerBall lottery	N=6
FAA design for aircraft	N=9-12

Cascading Faults

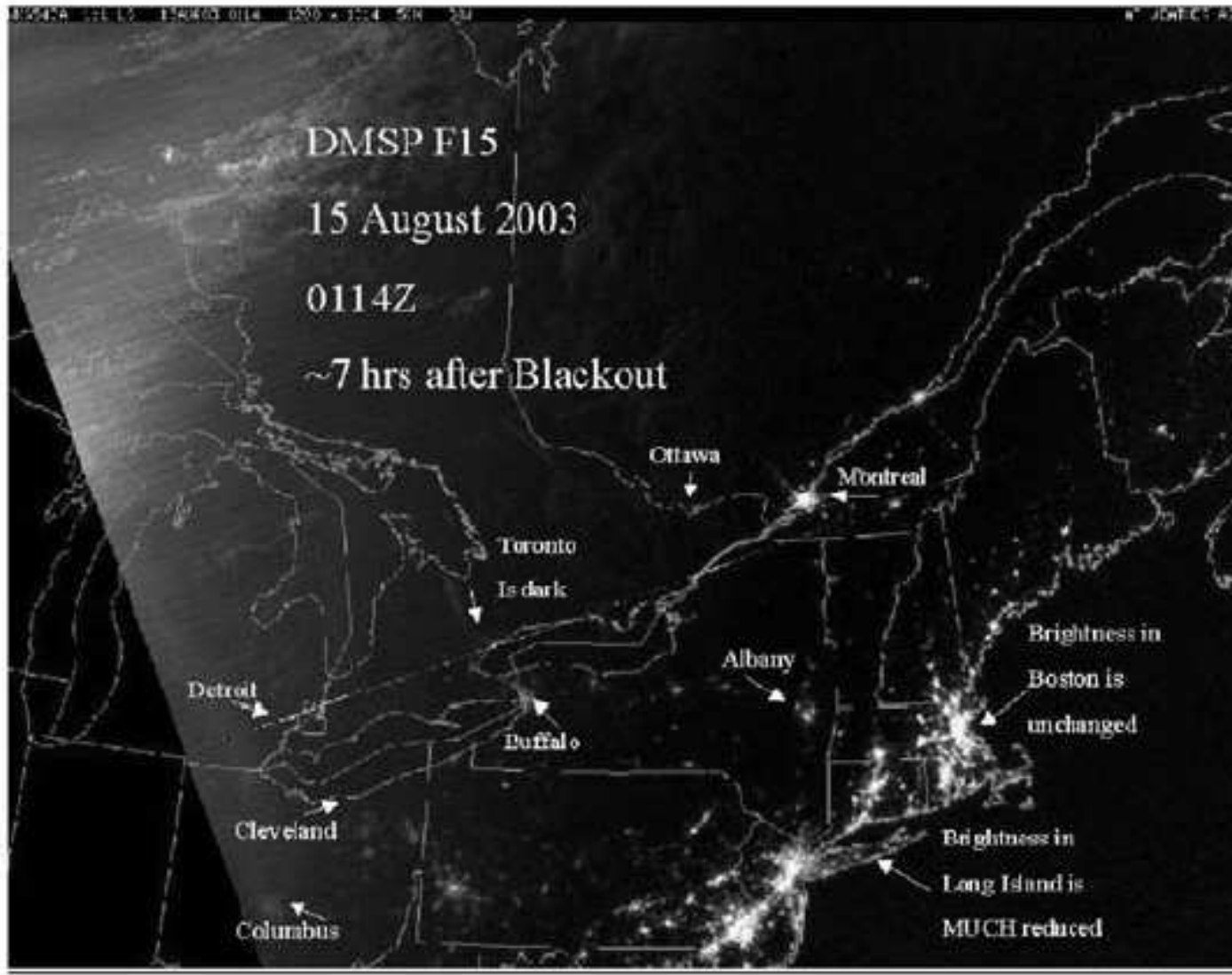

NAE Grand Challenges

NAE: “The vast networks of electrification are the greatest engineering achievement of the 20-th century.”

NAE Grand Challenges

NAE: “The vast networks of electrification are the greatest engineering achievement of the 20-th century.”

14 grand challenges for engineering in the 21-st century (Feb. 2008):

- 1. Environmentally friendly power.
- 2. Nuclear fusion.
- 3. Carbon dioxide sequestration.
- 6. Sustaining the aging infrastructure.

NAE Grand Challenges

NAE: “The vast networks of electrification are the greatest engineering achievement of the 20-th century.”

14 grand challenges for engineering in the 21-st century (Feb. 2008):

- 1. Environmentally friendly power.
- 2. Nuclear fusion.
- 3. Carbon dioxide sequestration.
- 6. Sustaining the aging infrastructure.

“Electricity will be much more prominent in the new energy economy” - L.R. Brown, *Plan B 3.0*

Electric Energy Networks

- Built for **efficiency**.
- **Multi-scale** in time (>10 orders of magnitude), space (>7 orders of magnitude) and by power flow (>10 orders of magnitude).
- **Hybrid** - continuous and discrete acting components.
- **Normal** and **faulted** operation (nature and human adversaries).

Electric Energy Networks

- Built for **efficiency**.
- **Multi-scale** in time (>10 orders of magnitude), space (>7 orders of magnitude) and by power flow (>10 orders of magnitude).
- **Hybrid** - continuous and discrete acting components.
- **Normal** and **faulted** operation (nature and human adversaries).
- Two main layers - **energy** and **information** flow.
- Limited actuation.
- **Uncertainty** (epistemic and aleatory).
- Input/Output characteristics are **regularized** by physics (conservation laws, coherences and invariants).

Existing Electric Energy Systems

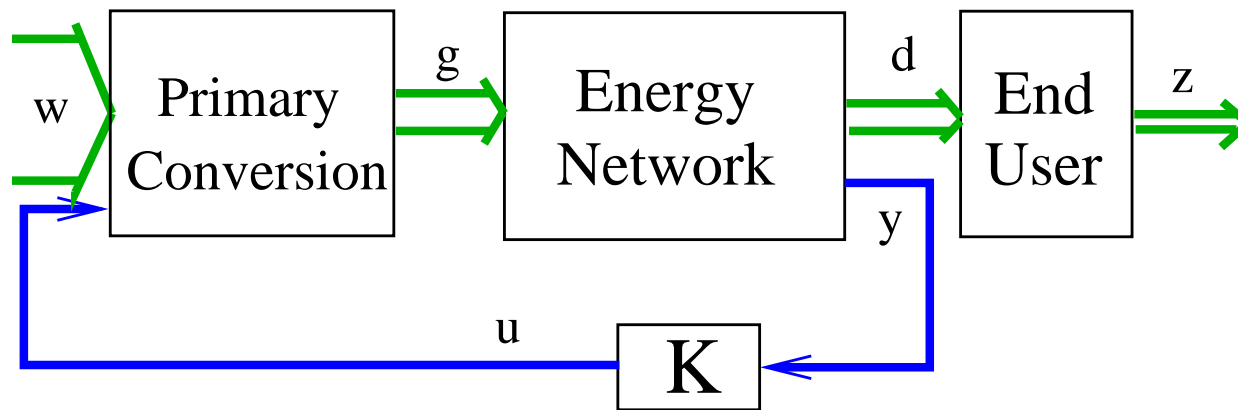

Existing Electric Energy Systems

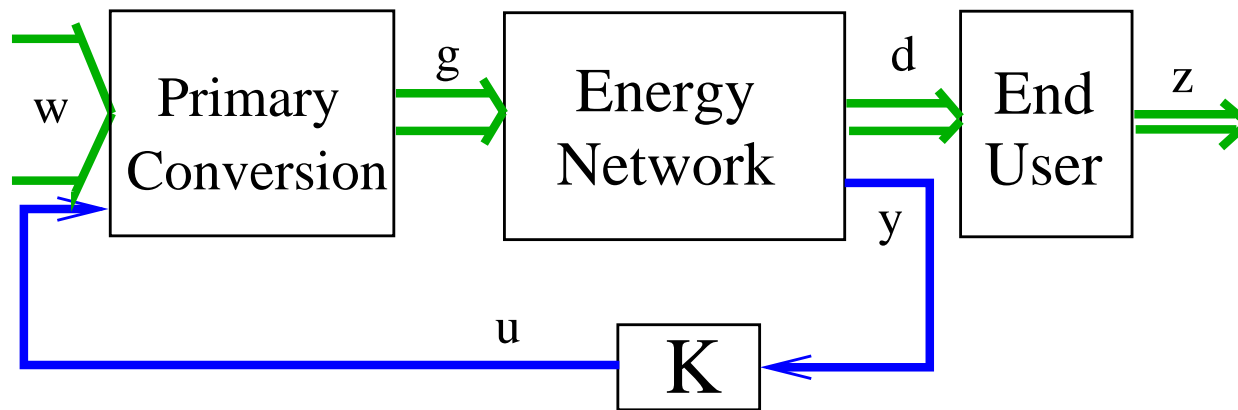

- w too large, **little** from renewables,
- **Unable** to integrate novel components,
- Non-functional **markets**,
- **Over-designed** components - variations in z ,
- **Over-designed** components - **fault** accommodation,
- **Cascading** faults.

Existing Energy Systems - Technical

- Not enough adaptation due to the insufficient information layer - control is **too local**, sometimes myopic,
- Significant **variations** in the part of w from **renewables** - large bandwidth and stochastic nature,
- No storage - a slow system is tracking variable z ,
- Large variations in z (and w) - cyclic and stochastic,
- Individual blocks have substantial **losses**,

Existing Energy Systems - Technical

- Not enough adaptation due to the insufficient information layer - control is **too local**, sometimes myopic,
- Significant **variations** in the part of w from **renewables** - large bandwidth and stochastic nature,
- No storage - a slow system is tracking variable z ,
- Large variations in z (and w) - cyclic and stochastic,
- Individual blocks have substantial **losses**,
- The inflexible overall architecture sometimes results in **complex behavior** - the system is very large, and the control authority is limited,
- **Legacy** components stifle innovation.
- Fault accommodation in **slow** hardware.

Grand Challenges in Energy Engineering

IEEE Power Engineering Society, 2002:

- 1. Total control of power flow in networked systems.
- 2. Self-healing networks to achieve zero outages.
- 3. Zero-error state estimation.
- 10. Real time dynamic simulation of a 50 000 node, 2 000 generator, 500 000 MW system.

Presentation Map

- Energy Systems - Past & Present,
- A Personal Interlude - Dynamic Phasors,
- Energy Systems - Future.

Definitions

$x(t - \Delta)$ on the interval $[0 \leq \Delta < T_0)$ via (short-time) Fourier series:

$$x(t - \Delta) = \sum_{k=-\infty}^{\infty} X_k(t) e^{jk\omega_0(t-\Delta)} = \sum_{k=-\infty}^{\infty} e^{-jk\omega_0\Delta} \mathcal{X}_k(t)$$

$X_k(t)$ are the complex, time-varying Fourier coefficients, or **dynamic phasors**.

Definitions

$x(t - \Delta)$ on the interval $[0 \leq \Delta < T_0)$ via (short-time) Fourier series:

$$x(t - \Delta) = \sum_{k=-\infty}^{\infty} X_k(t) e^{jk\omega_0(t-\Delta)} = \sum_{k=-\infty}^{\infty} e^{-jk\omega_0\Delta} \mathcal{X}_k(t)$$

$X_k(t)$ are the complex, time-varying Fourier coefficients, or **dynamic phasors**.

$$X_k(t) = \frac{1}{T_0} \int_{t-T_0}^t x(\tau) e^{-jk\omega_0\tau} d\tau = \langle x \rangle_k(t)$$

We model **dynamics** of $X_k(t)$; for real $x(\cdot)$ we have $X_{-k} = X_k^*$

A Simple Example

Consider a simple RL circuit ($R=0.1$, $L=0.002$) with a \sin excitation ($V=10$), at 60Hz

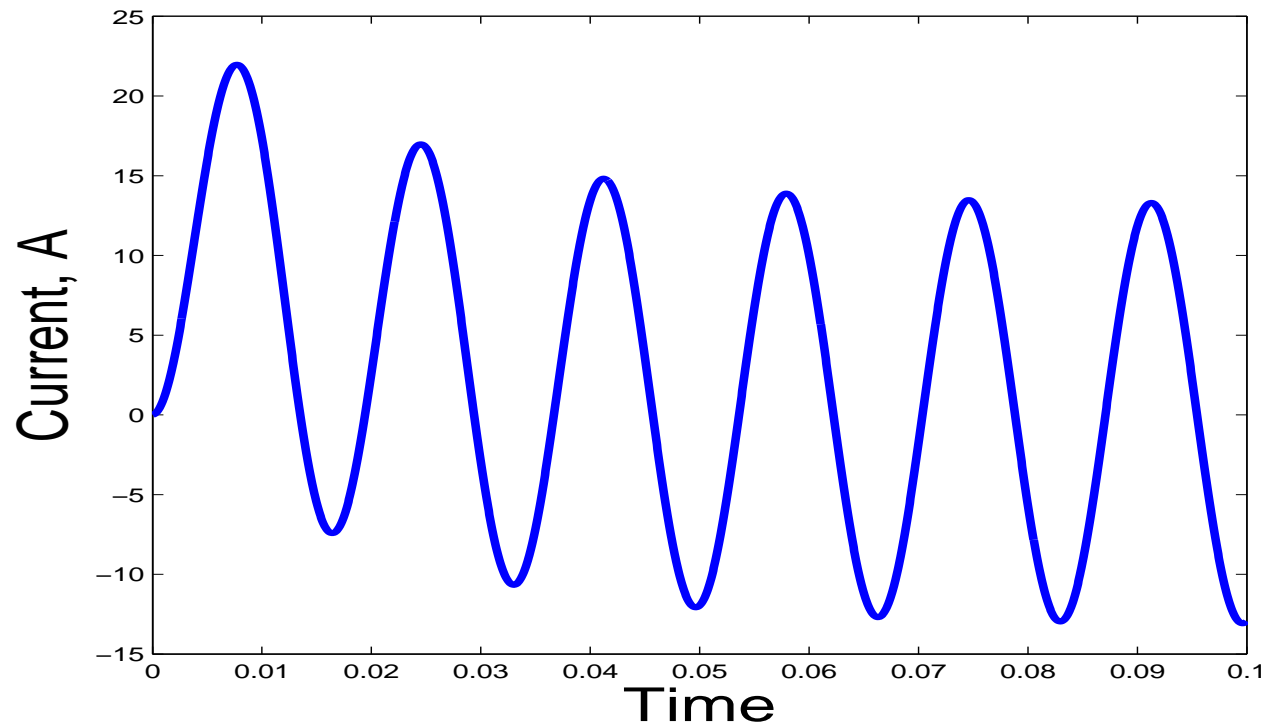

A Simple Example

The dynamic phasors (according to our definition)

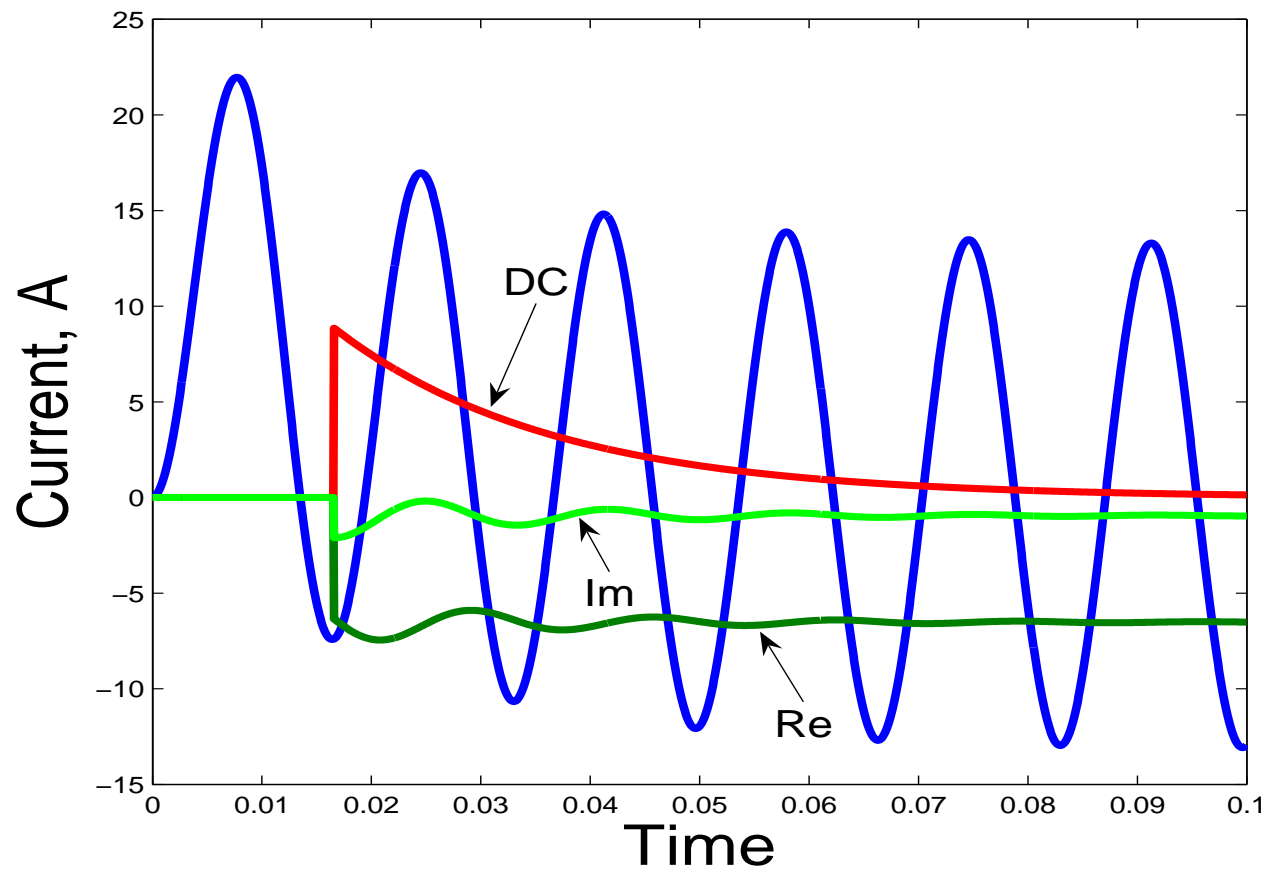

Basic Results

Two useful facts:

Derivative of the k -th dynamic phasor:

$$\frac{dX_k}{dt} = \left\langle \frac{d}{dt} x \right\rangle_k - j k \omega_0 X_k$$

Multiplication in time domain:

$$\langle xy \rangle_k = \sum_l \langle x \rangle_{k-l} \langle y \rangle_l$$

Dynamics of Local Coefficients

$\mathcal{X}_k(t)$ as the output of an LTI filter:

$$\mathcal{X}_k(t) = \int_{-\infty}^{\infty} x(\tau) [h(t - \tau) e^{jk\omega_0(t-\tau)}] d\tau$$

where $h(\cdot)$ is a rectangular window (width T_0 , height $1/T_0$) \implies
translation of state-space representations - if

$$\dot{x}(t) = Ax(t) + Bu(t)$$

then

$$\dot{\mathcal{X}}_k(t) = A\mathcal{X}_k(t) + Bv_k(t)$$

Dynamics of Local Coefficients

$\mathcal{X}_k(t)$ as the output of an LTI filter:

$$\mathcal{X}_k(t) = \int_{-\infty}^{\infty} x(\tau) [h(t - \tau) e^{jk\omega_0(t-\tau)}] d\tau$$

where $h(\cdot)$ is a rectangular window (width T_0 , height $1/T_0$) \implies translation of state-space representations - if

$$\dot{x}(t) = Ax(t) + Bu(t)$$

then

$$\dot{\mathcal{X}}_k(t) = A\mathcal{X}_k(t) + Bv_k(t)$$

True for **any** filter bank representation – for dynamic phasors (since $X_k(t) = \mathcal{X}_k(t)e^{-jk\omega_0 t}$),

$$\dot{X}_k(t) = (A - jk\omega_0 I)X_k(t) + BU_k(t)$$

Flexible AC Transmission

Thyristor Controlled Series Capacitors (TCSCs) are finding increasing application in power systems.

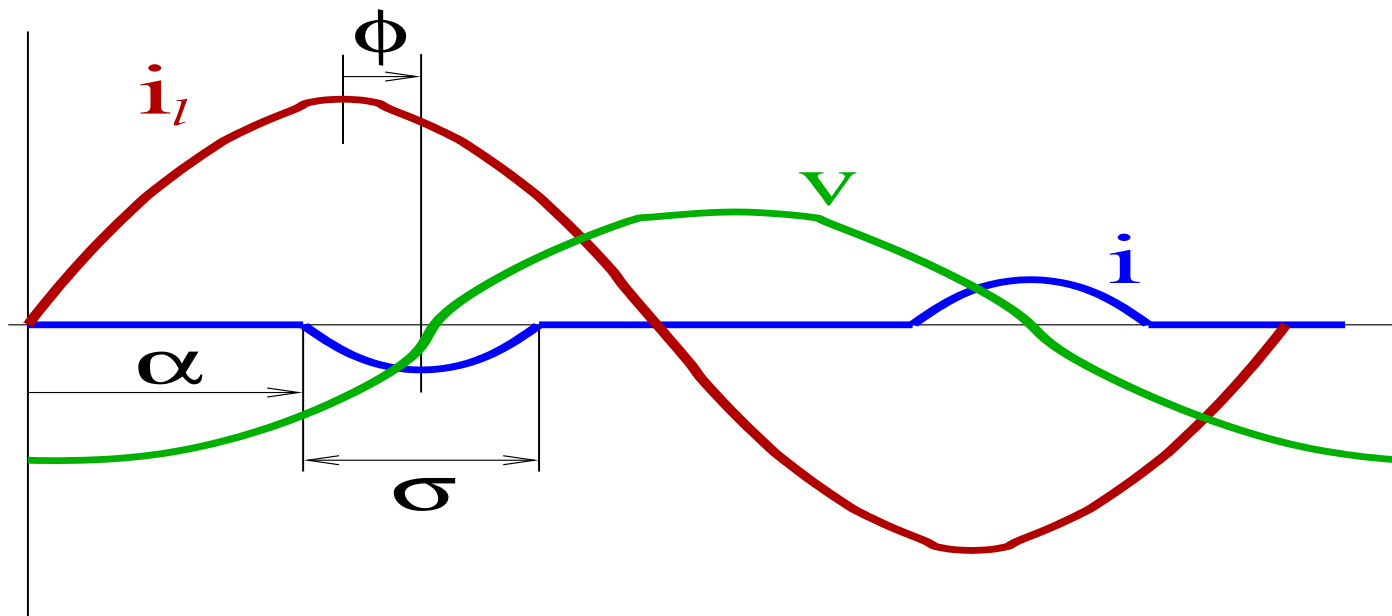
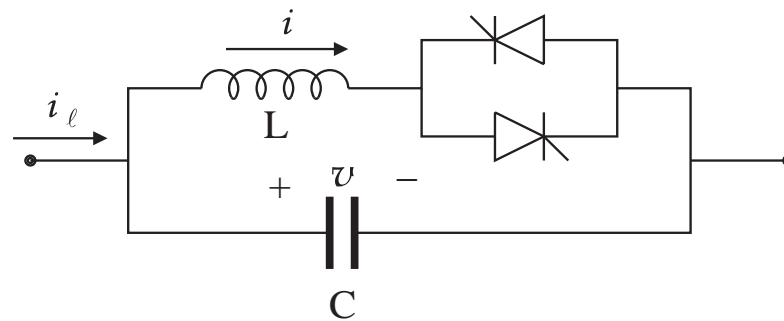

Flexible AC Transmission

A state-space model for TCSC:

$$C \frac{dv}{dt} = i_\ell - i$$
$$L \frac{di}{dt} = q v$$

where q is a 0 – 1 switching function.

Flexible AC Transmission

A state-space model for TCSC:

$$C \frac{dv}{dt} = i_\ell - i$$
$$L \frac{di}{dt} = q v$$

where q is a 0 – 1 switching function.

Evaluating the 1-phasor (and assuming i_ℓ sinusoidal), \implies 2nd-order (complex) phasor model:

$$C \frac{dV_1}{dt} = I_\ell - I_1 - j \omega_0 C V_1$$
$$L \frac{dI_1}{dt} = \langle q v \rangle_1 - j \omega_0 L I_1$$

where $\langle q v \rangle_1$ is:

$$\langle q v \rangle_1 = \frac{2}{\pi} \int_{\alpha}^{\alpha+\sigma} v e^{-j\theta} d\theta.$$

Flexible AC Transmission

I_1 has fast dynamics compared to V_1 , so $I_1 \approx V_1 / (j\omega_0 L_{eff}(\sigma))$

$$C \frac{dV_1}{dt} = I_\ell - \left(j\omega_0 C + \frac{1}{j\omega_0 L_{eff}(\sigma)} \right) V_1 = I_\ell - j\omega_0 C_{eff}(\sigma) V_1$$

where σ is the **prevailing conduction angle**

$$\sigma = \sigma^0 + 2\phi \approx \sigma^0 + 2 \arg [-jI_\ell (V_1)^*]$$

and σ^0 is the *control* reference.

C_{eff} from steady-state assuming sinusoidal line current i_ℓ .

Flexible AC Transmission

I_1 has fast dynamics compared to V_1 , so $I_1 \approx V_1 / (j\omega_0 L_{eff}(\sigma))$

$$C \frac{dV_1}{dt} = I_\ell - \left(j\omega_0 C + \frac{1}{j\omega_0 L_{eff}(\sigma)} \right) V_1 = I_\ell - j\omega_0 C_{eff}(\sigma) V_1$$

where σ is the **prevailing conduction angle**

$$\sigma = \sigma^0 + 2\phi \approx \sigma^0 + 2 \arg [-jI_\ell (V_1)^*]$$

and σ^0 is the *control* reference.

C_{eff} from steady-state assuming sinusoidal line current i_ℓ .

$$C_{eff}(\sigma) = \left[\frac{1}{C} - \frac{4}{\pi} \left(\frac{1}{2C} \mathcal{S} \left(\sigma + \frac{\sin(2\sigma)}{2} \right) + \omega_0^2 L \mathcal{S}^2 \cos^2(\sigma) (\tan(\sigma) - \eta \tan(\eta\sigma)) \right) \right]^{-1}$$

where $\eta = \frac{\Omega_0}{\omega_0}$, $\Omega_0 = \sqrt{\frac{1}{LC}}$ and $\mathcal{S} = \frac{\eta^2}{\eta^2 - 1}$.

Subsynchronous Resonance

First IEEE benchmark test:

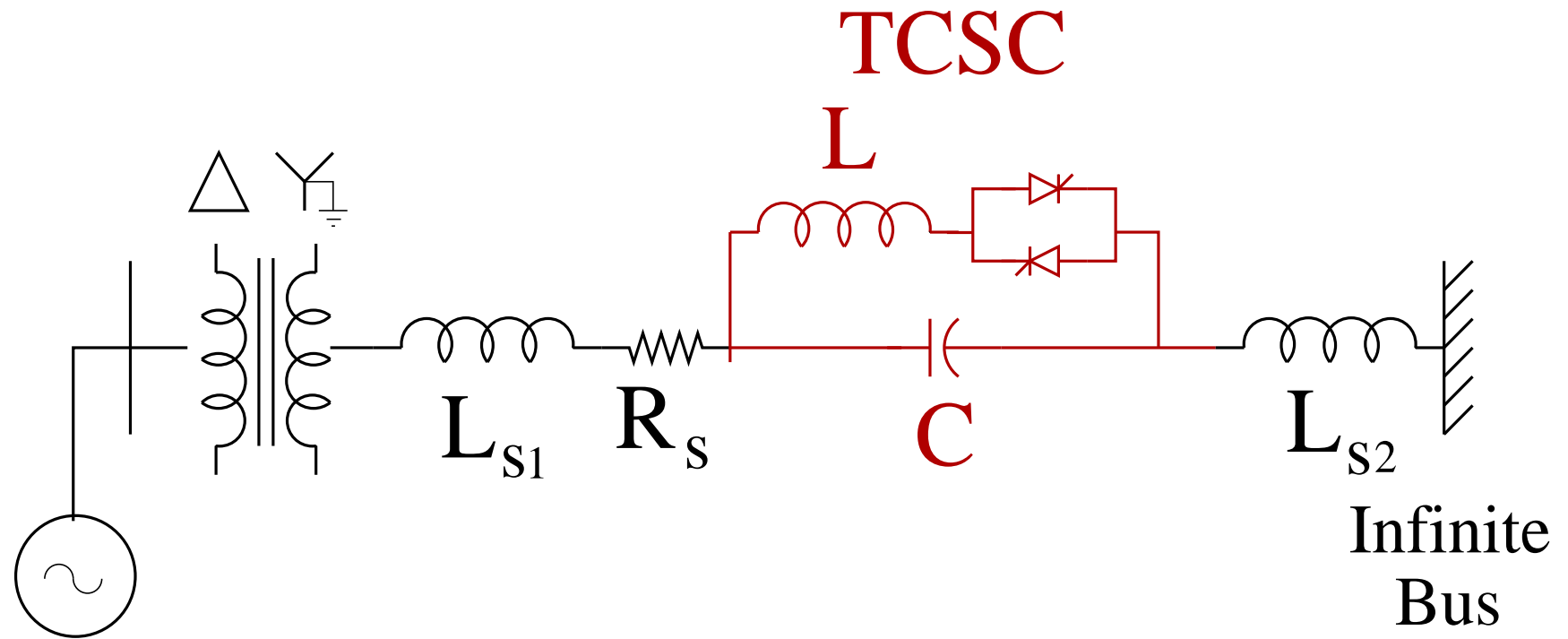

Subsynchronous Resonance

TCSC model without (solid line) and with the phase correction (dashed line); “o” sampled-data for the *equidistant* synchronization:

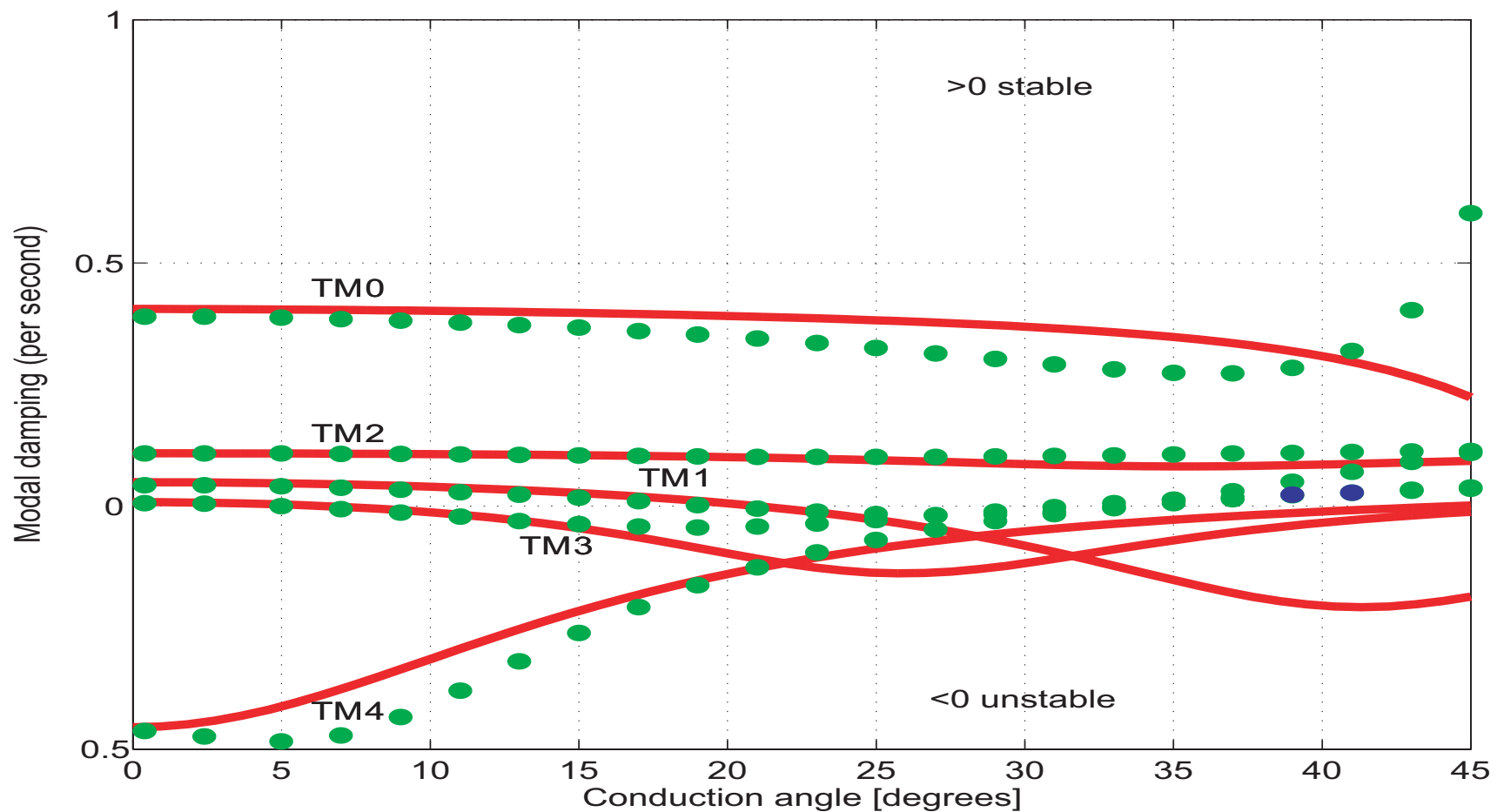

Subsynchronous Resonance

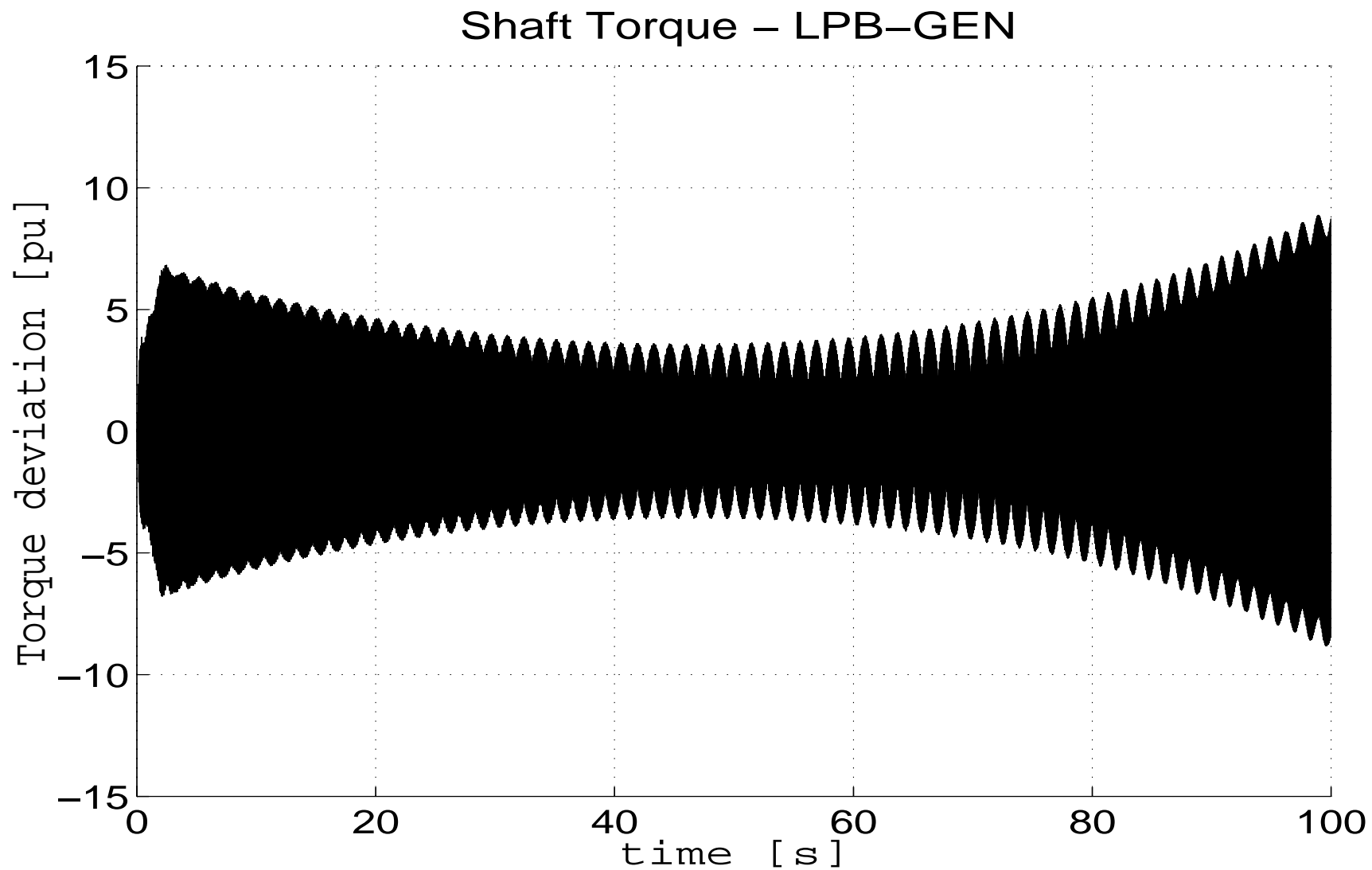

Subsynchronous Resonance

Expanded view (between 80s and 81s) of torque variations

Shaft torque at different shaft positions

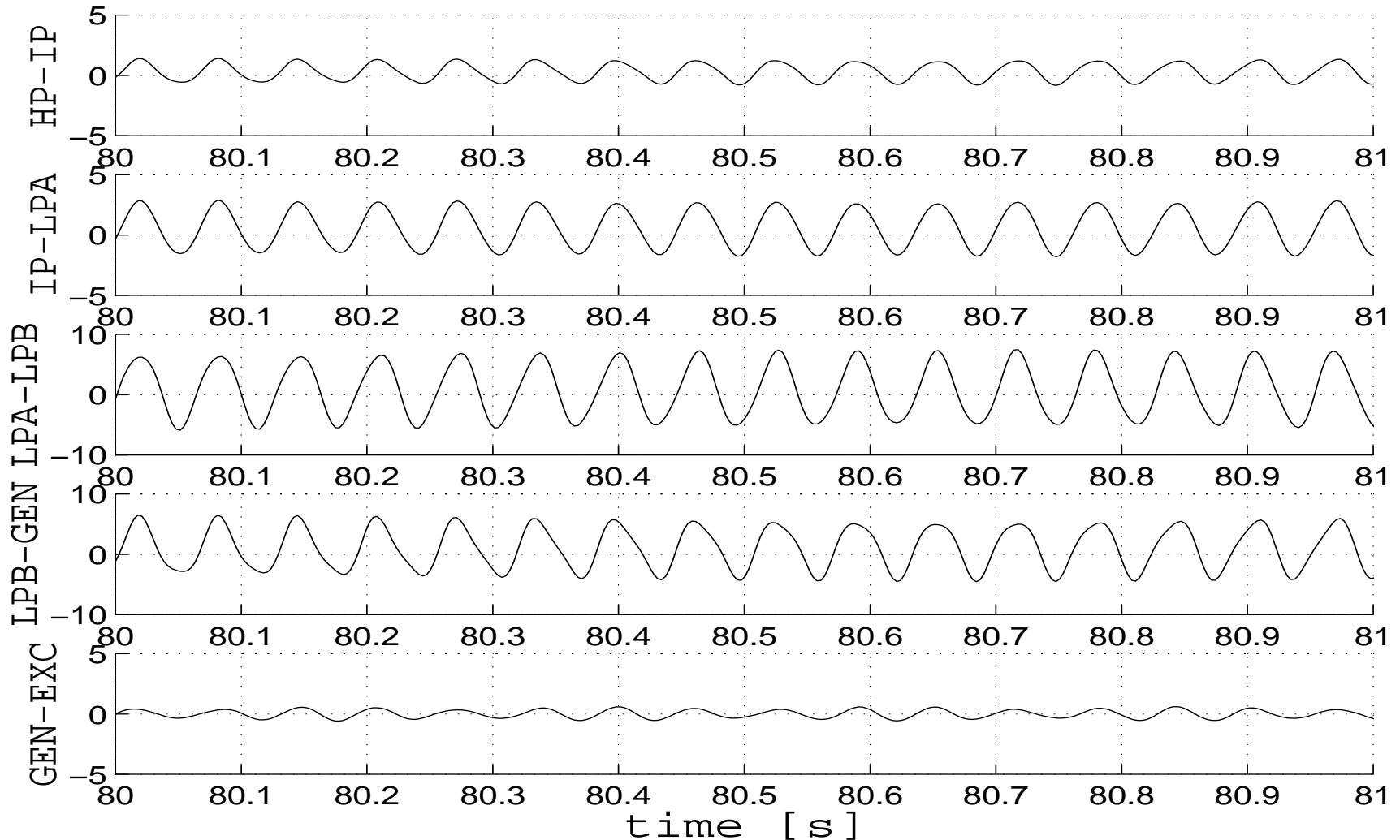

Extensions - Classical

Dynamic symmetrical components - recall $\alpha = e^{j\frac{2\pi}{3}}$,

$$\begin{bmatrix} x_a \\ x_b \\ x_c \end{bmatrix} (\tau) = \sum_{k=-\infty}^{\infty} e^{jk\omega_0\tau} \underbrace{\frac{1}{\sqrt{3}} \begin{bmatrix} 1 & 1 & 1 \\ \alpha^* & \alpha & 1 \\ \alpha & \alpha^* & 1 \end{bmatrix}}_F \begin{bmatrix} X_{p,k} \\ X_{n,k} \\ X_{z,k} \end{bmatrix} (t)$$

$$\begin{bmatrix} X_{p,k} \\ X_{n,k} \\ X_{z,k} \end{bmatrix} (t) = \frac{1}{T_0} \int_{t-T_0}^t e^{-jk\omega_0\tau} F^H \begin{bmatrix} x_a \\ x_b \\ x_c \end{bmatrix} (\tau) d\tau = \begin{bmatrix} \langle x \rangle_{p,k} \\ \langle x \rangle_{n,k} \\ \langle x \rangle_{z,k} \end{bmatrix} (t).$$

$$\frac{d}{dt} \begin{bmatrix} X_{p,k} \\ X_{n,k} \\ X_{z,k} \end{bmatrix} (t) = F^H \begin{bmatrix} \langle \frac{d}{d\tau} x_a(\tau) \rangle_k \\ \langle \frac{d}{d\tau} x_b(\tau) \rangle_k \\ \langle \frac{d}{d\tau} x_c(\tau) \rangle_k \end{bmatrix} (t) - jk\omega_0 \begin{bmatrix} X_{p,k} \\ X_{n,k} \\ X_{z,k} \end{bmatrix} (t)$$

Extensions - Phasor Banks

With H. Lev-Ari – in discrete-time, standard definitions lead to (discrete-time) Gabor Transform – **non-decimated** DFT analysis and synthesis banks:

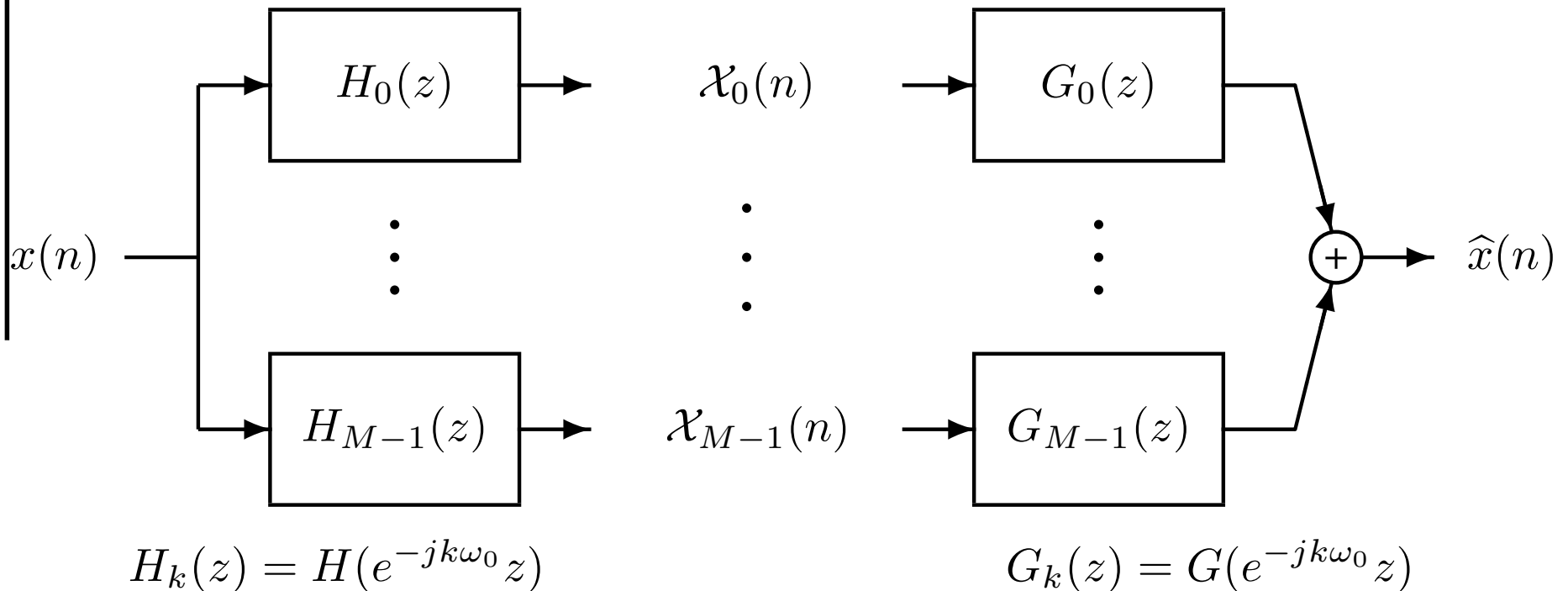

Phasor Banks (2)

An example - a fundamental and a slowly modulated third harmonic:

$$x(n) = 2 \cos(\omega_0 n) + a(n) \sin(3\omega_0 n)$$

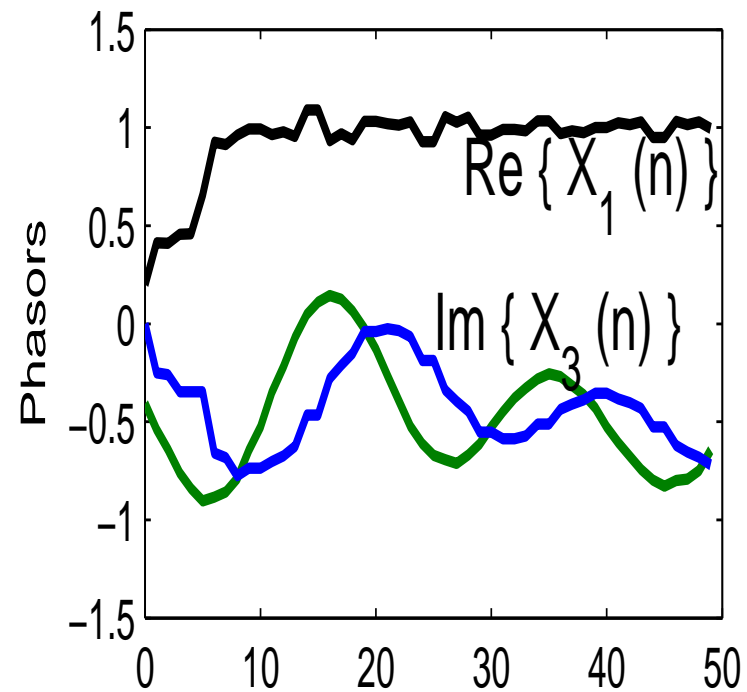
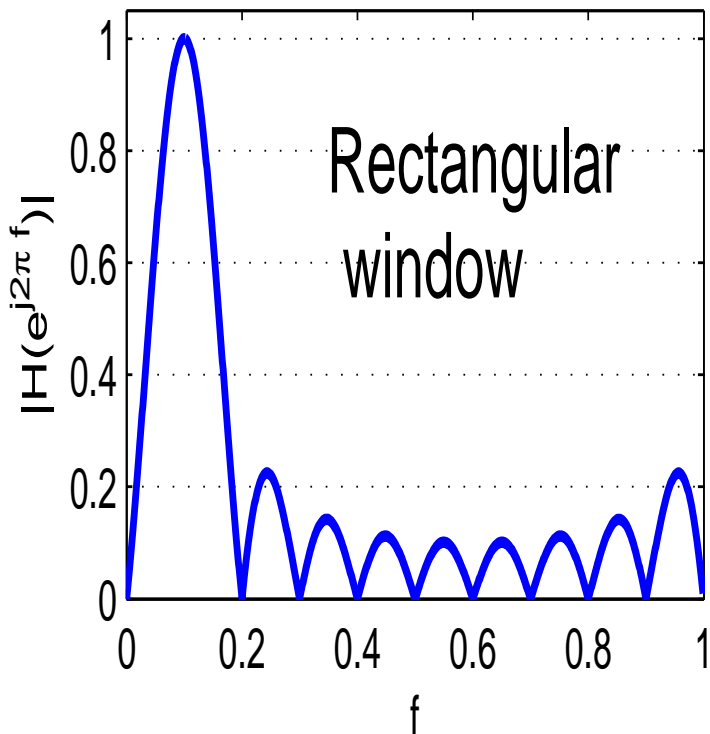

Phasor Banks (3)

The same example:

$$x(n) = 2 \cos(\omega_0 n) + a(n) \sin(3\omega_0 n)$$

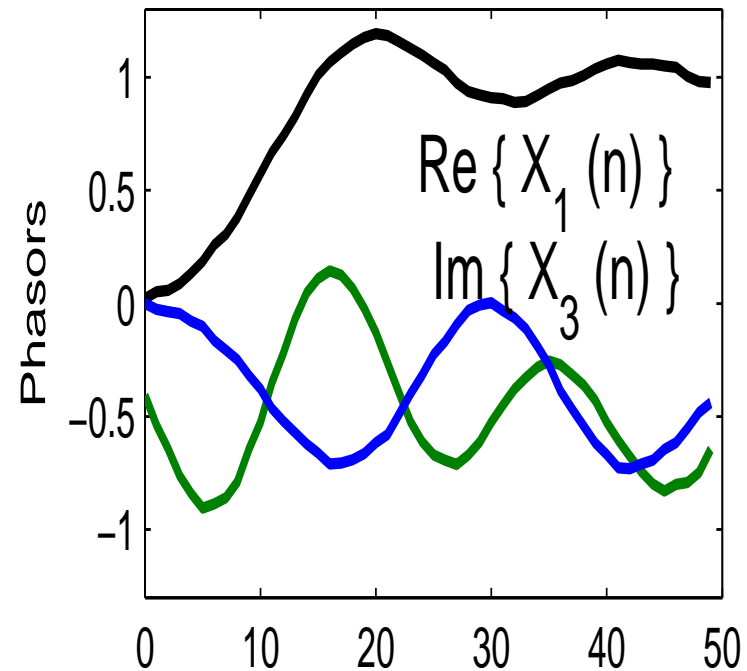
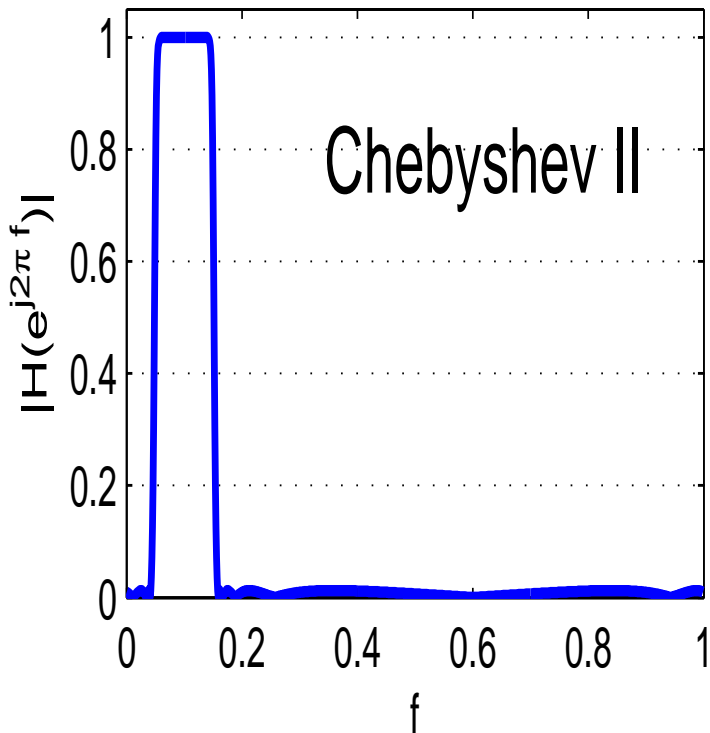

Other Applications

Power electronics:

- DC/DC converters (model reduction),
- Resonant converters,
- Active filters,
- High-power converters - Unified Power Factor Controller.

Electric Drives:

- Unbalanced electrical machines,
- Torque ripple minimization,
- Position-dependent loads.

Power Systems:

- Unbalanced faults - dynamic symmetrical components,
- Model-based estimation,
- Protection.

Presentation Map

- Energy Systems - Past & Present,
- A Personal Interlude - Dynamic Phasors,
- Energy Systems - Future.

Existing Energy Systems

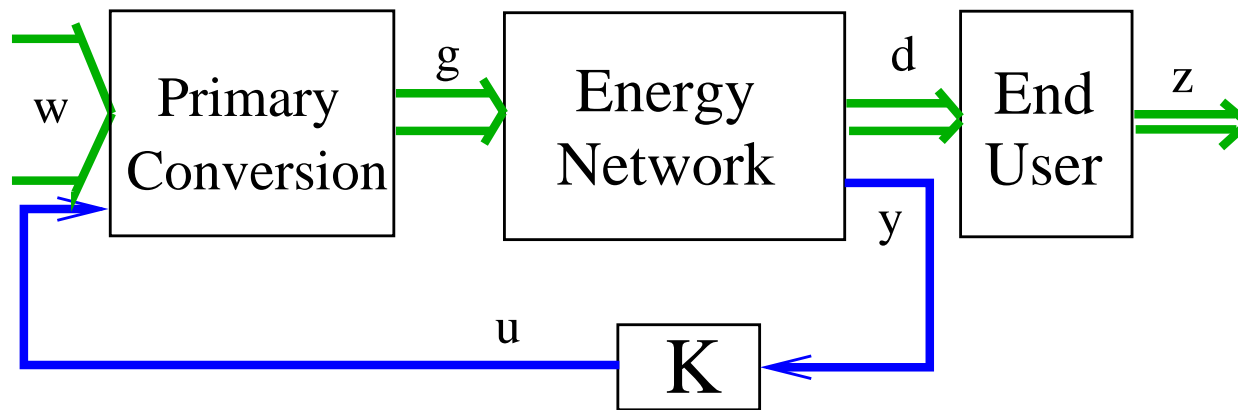

Future Energy Systems VLSIE

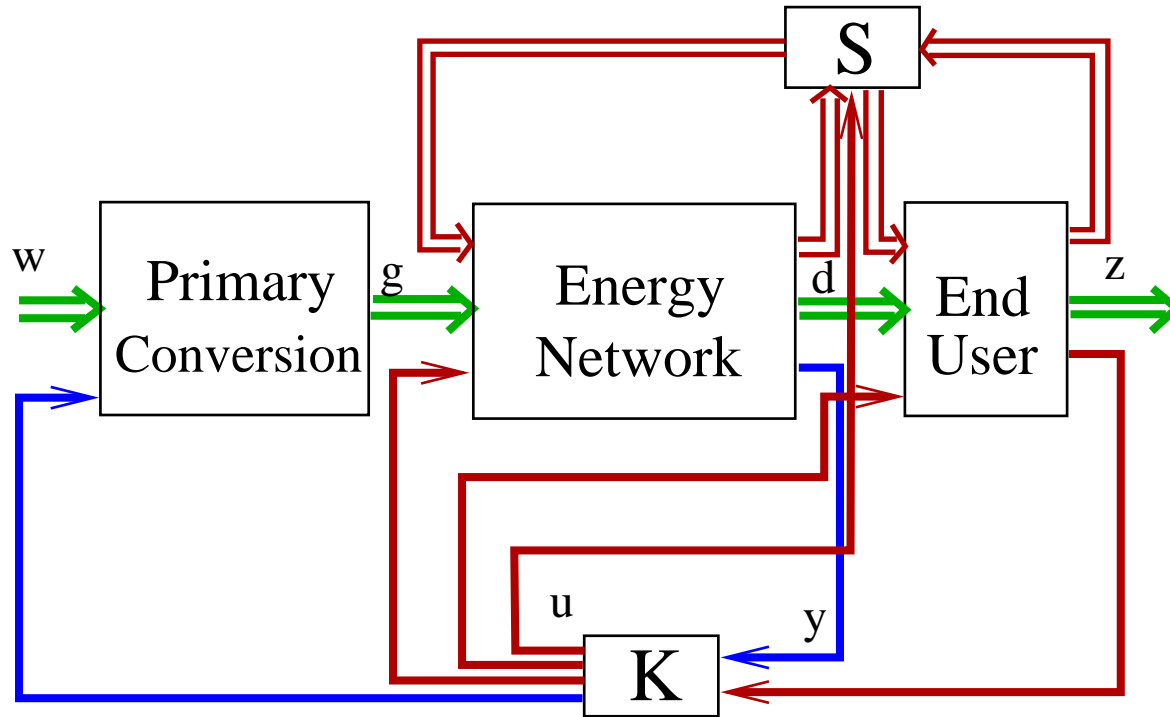

Future Energy Systems VLSIE

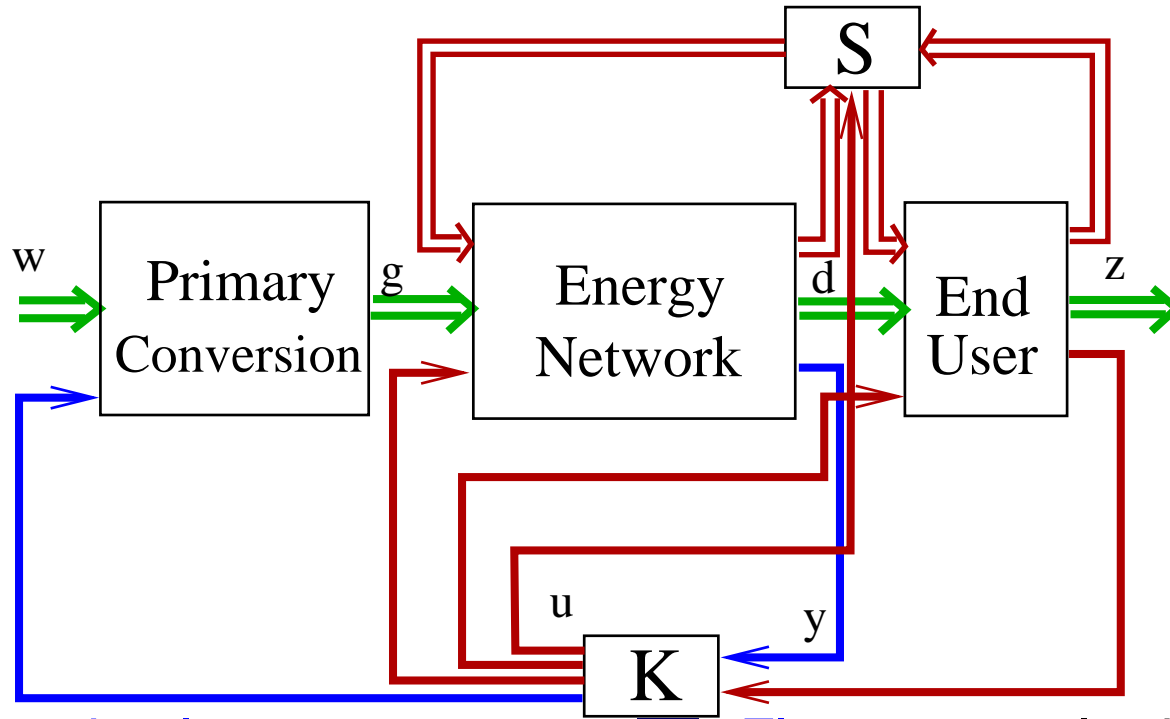

- **Information layer**
 (sensors, coordinated K = local + global context, loads inside)
- **Better blocks,**
- **More w from renewables,**

- **Flatter control** - decoupling from above and below, faster, more authority via storage and routing,
- **Better design** while steering component development.

Grand Interconnection

Society uses **multiple** energy carriers - electricity, natural gas, liquid fuels, hydrogen. This helps security, but the lack of coordination results in: 1) excess consumption, 2) inefficiencies and 3) lack of incentives to move to renewables.

Grand Interconnection

Society uses **multiple** energy carriers - electricity, natural gas, liquid fuels, hydrogen. This helps security, but the lack of coordination results in: 1) excess consumption, 2) inefficiencies and 3) lack of incentives to move to renewables.

Networked multi-carrier energy hubs - by connecting and coordinating different single-carrier systems in cyber-physical networks (i.e., at the energy and the information flow layers) overall performance can be dramatically improved.

Grand Interconnection

Society uses **multiple** energy carriers - electricity, natural gas, liquid fuels, hydrogen. This helps security, but the lack of coordination results in: 1) excess consumption, 2) inefficiencies and 3) lack of incentives to move to renewables.

Networked multi-carrier energy hubs - by connecting and coordinating different single-carrier systems in cyber-physical networks (i.e., at the energy and the information flow layers) overall performance can be dramatically improved.

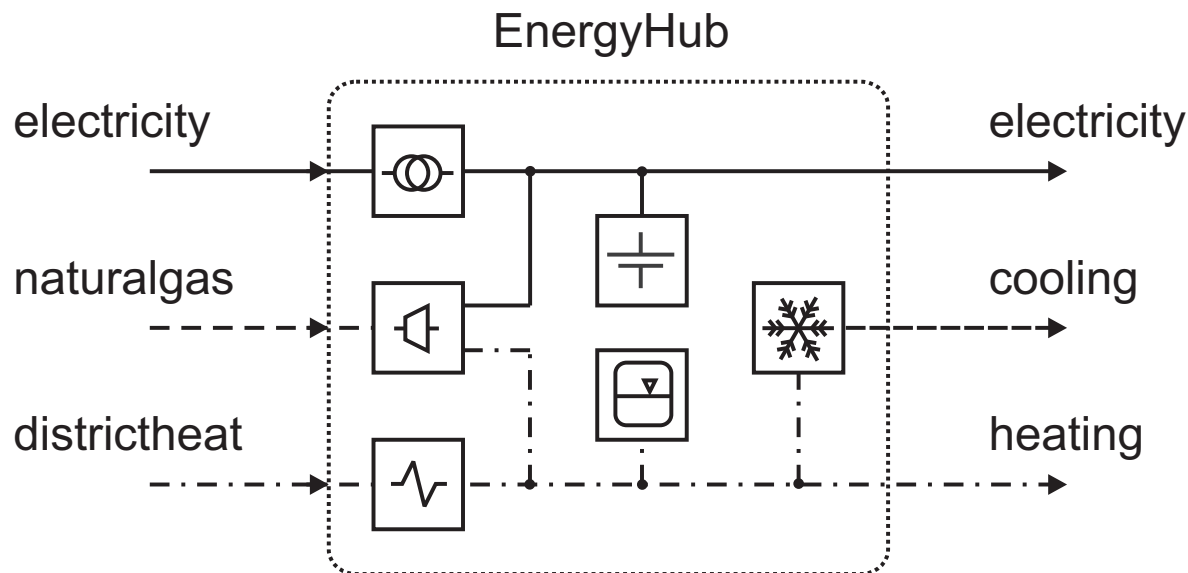

Future...

A new positioning of energy processing within EE (C. Gellings):

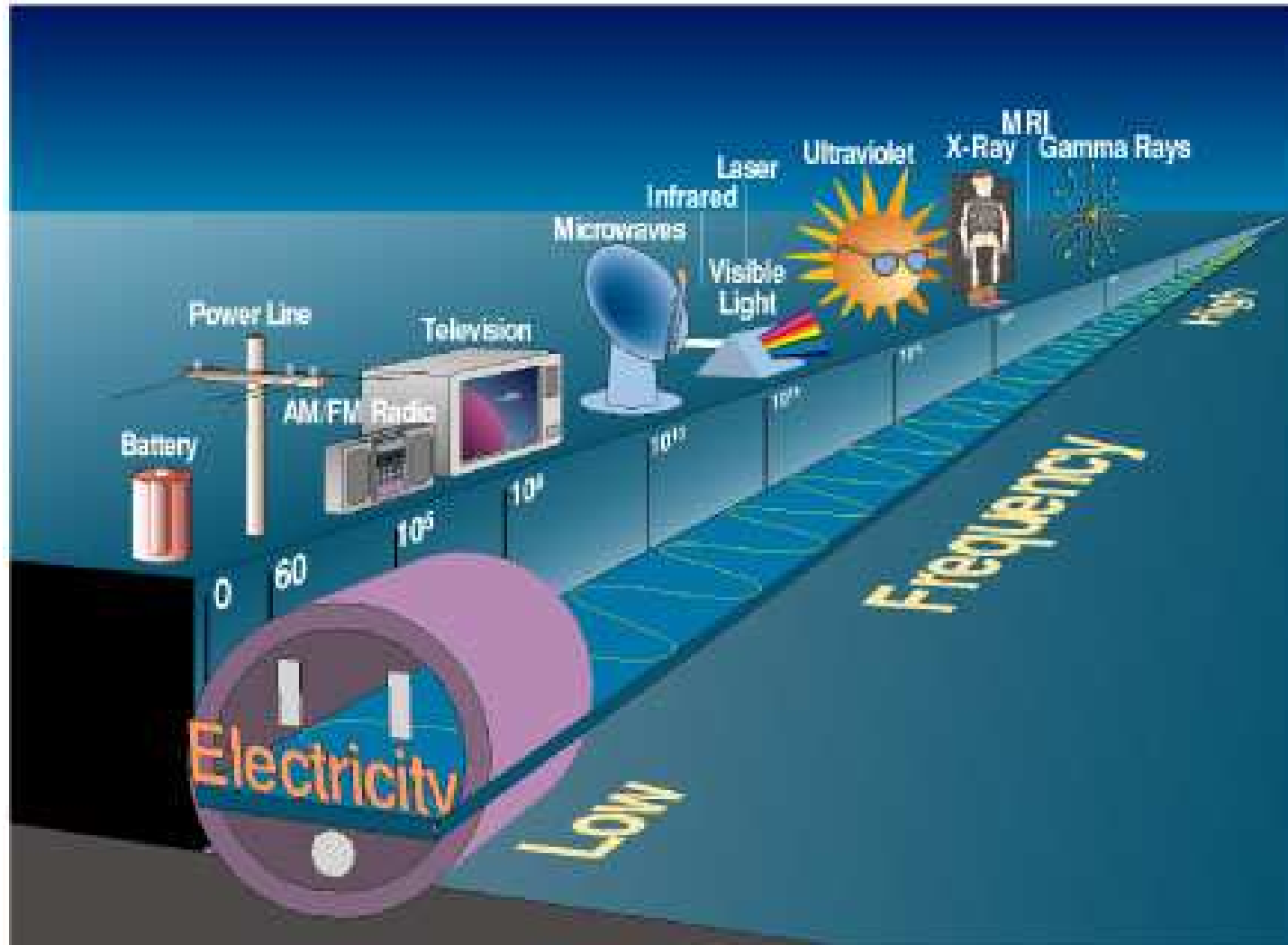

Getting there...

- Progress of technology in energy systems - “like visiting a graveyard in the company of Nietzsche” (Willems),

Getting there...

- Progress of technology in energy systems - “like visiting a graveyard in the company of Nietzsche” (Willems),
- Society expects 1) carbon-free electricity, 2) networks resilient to outages, and 3) functional markets and public policy.

Getting there...

- Progress of technology in energy systems - “like visiting a graveyard in the company of Nietzsche” (Willems),
- Society expects 1) carbon-free electricity, 2) networks resilient to outages, and 3) functional markets and public policy.
- The efficiency is determined by the energy flow layer,
- **Key enablers** for improvement are in the information flow layer,
- The trajectory to future energy systems will be economy and policy driven (e.g., energy levels for sensors vs. storage).

Getting there...

- Progress of technology in energy systems - “like visiting a graveyard in the company of Nietzsche” (Willems),
- Society expects 1) carbon-free electricity, 2) networks resilient to outages, and 3) functional markets and public policy.
- The efficiency is determined by the energy flow layer,
- **Key enablers** for improvement are in the information flow layer,
- The trajectory to future energy systems will be economy and policy driven (e.g., energy levels for sensors vs. storage).
- “The energy crisis appears to me to be more a crisis of momentum than of energy – a crisis of enterprise, solidarity, common spirit, determination and cooperation for the common good.” - Ulam

ACKNOWLEDGMENTS

My heartfelt thanks to [H. Lev-Ari \(NU\)](#) for research collaborations and to many colleagues and former students consulted about energy systems: M. Amin, G. Andersson, T. Aydin, M. Begovic, D. Boroyevich, C. DeMarco, I. Dobson, G. Escobar, J. Hauer, D. Hill, M. Ilic, C. Jacobson, I. Kamwa, J. Kolar, P. Kokotovic, B. Krogh, J. Lang, P.-A. Lof, N. Martins, P. Mattavelli, M. Morari, M.A. Pai, M. Perisic, R. Ortega, N. Rau, J. Sanchez-Gasca, A. Saric, P. Sauer, S. Sanders, A. Sangiovanni-Vincentelli, D. Siljak, C. Taylor, G. Verghese, F. Wu.

Contact info:

astankov@ece.neu.edu

www.ece.neu.edu/faculty/stankovic

Electricity in the U.S.

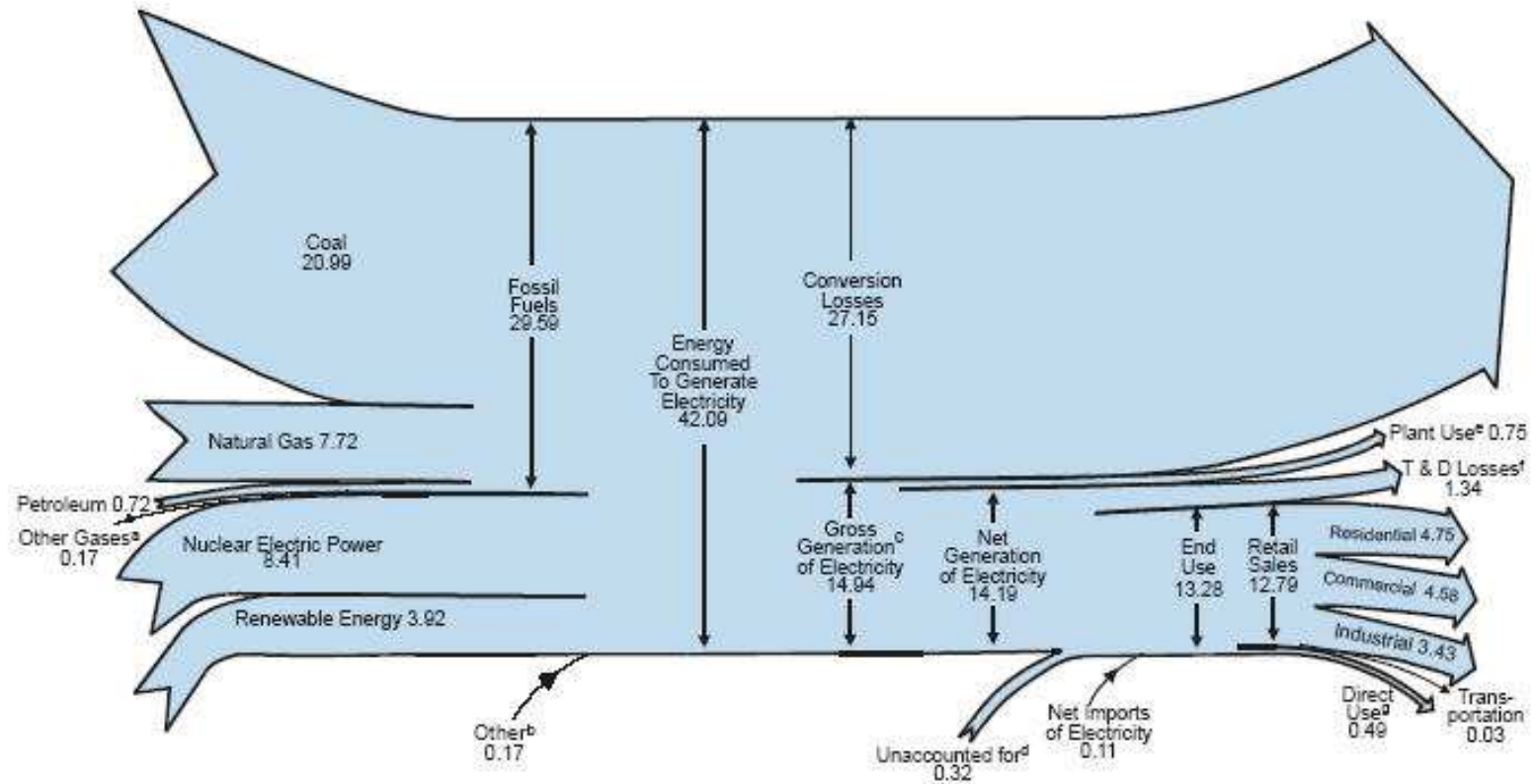

A Similar Plot...

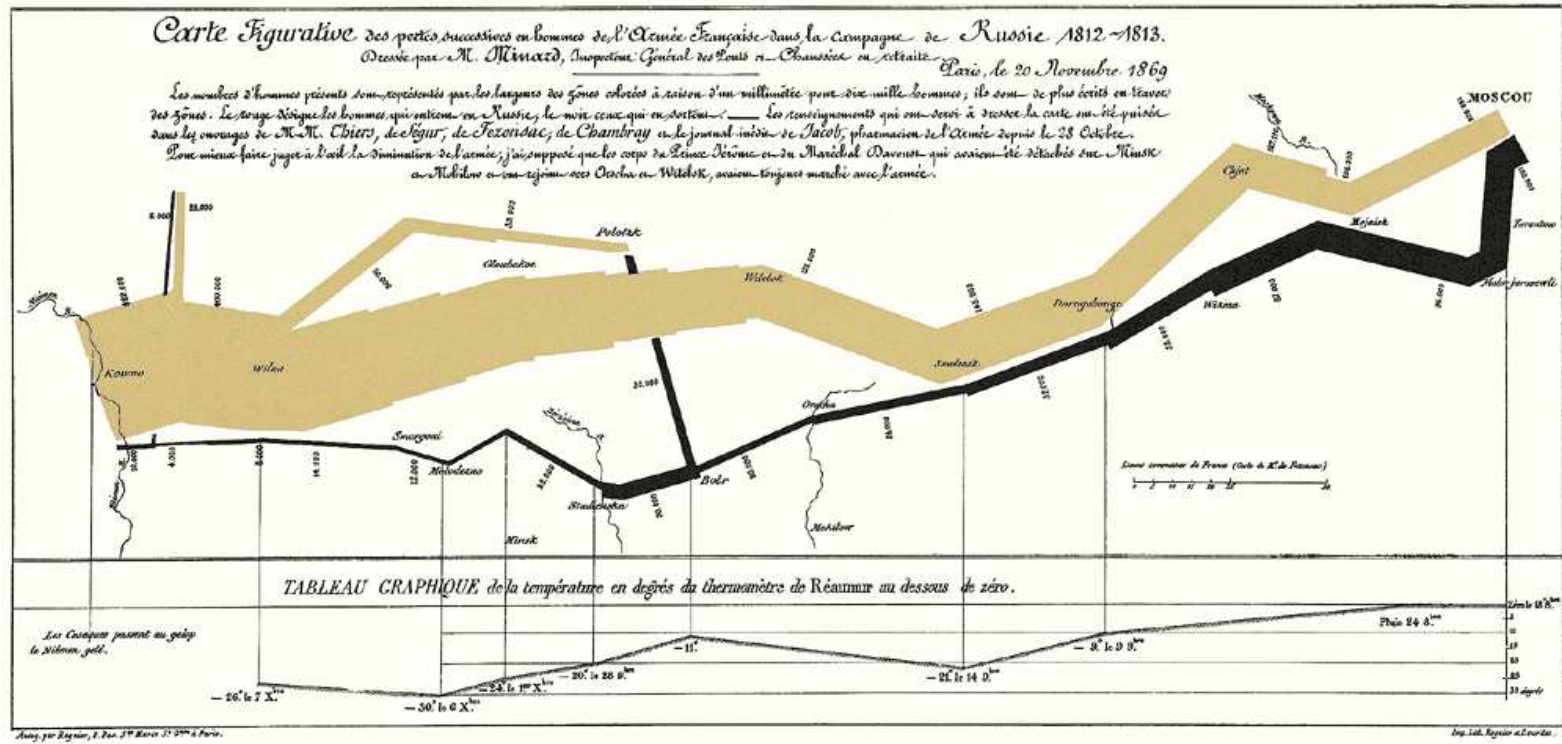

Napoleon in Russia, illustration by Minard.

Overall Energy Flows

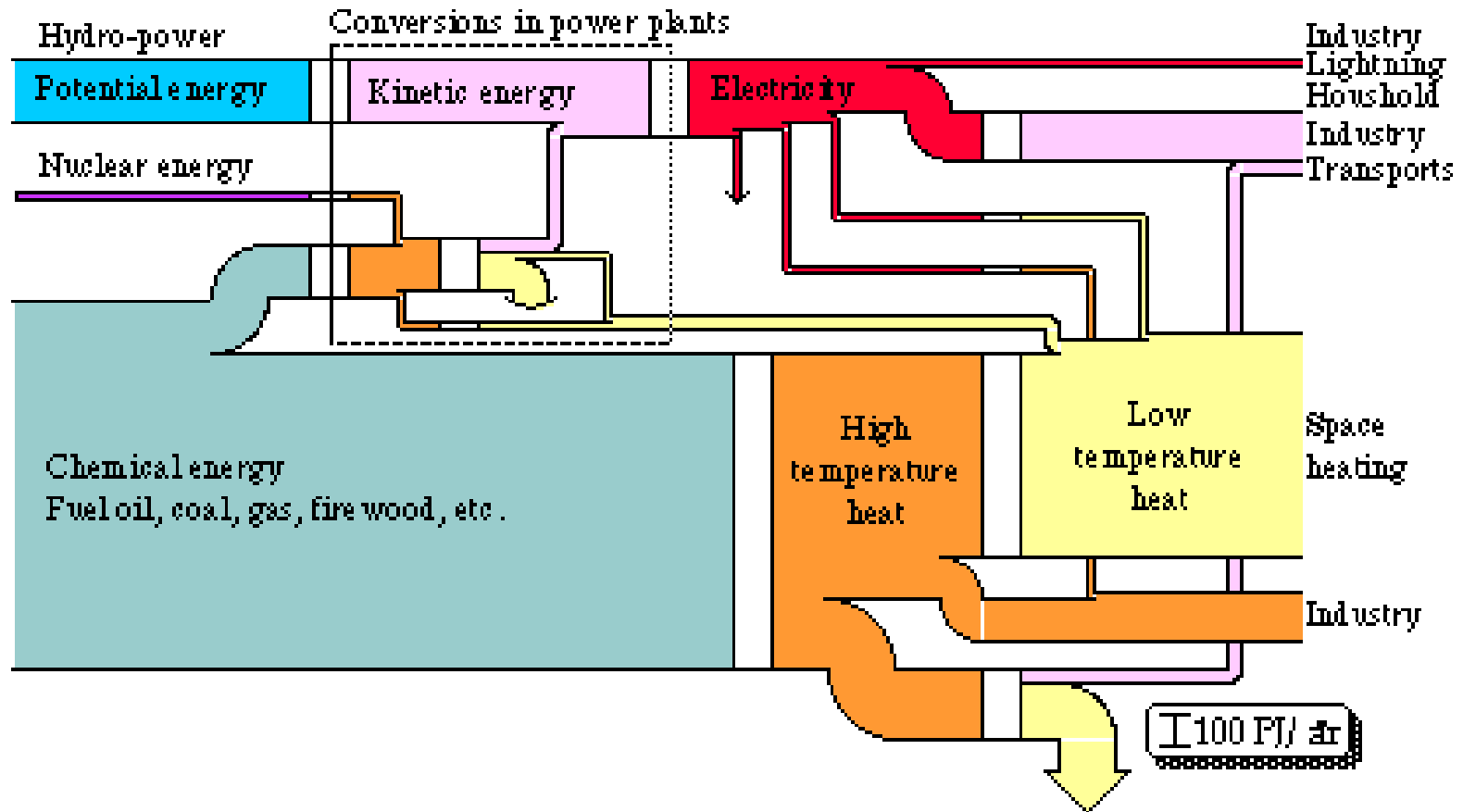

Primary Sources

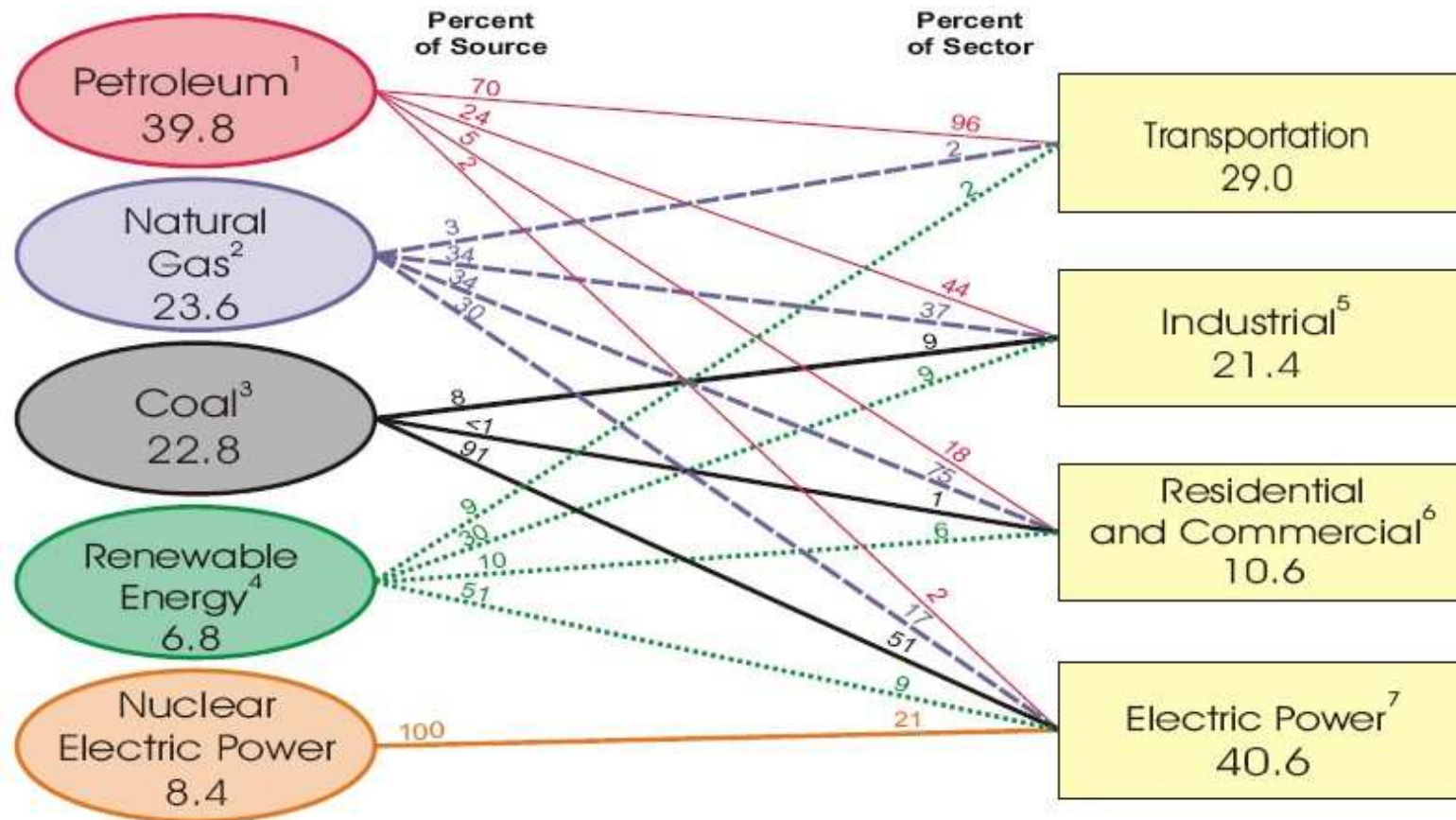

Energy Flows in the U.S.

U.S. Energy Flow Trends – 2002 Net Primary Resource Consumption ~97 Quads

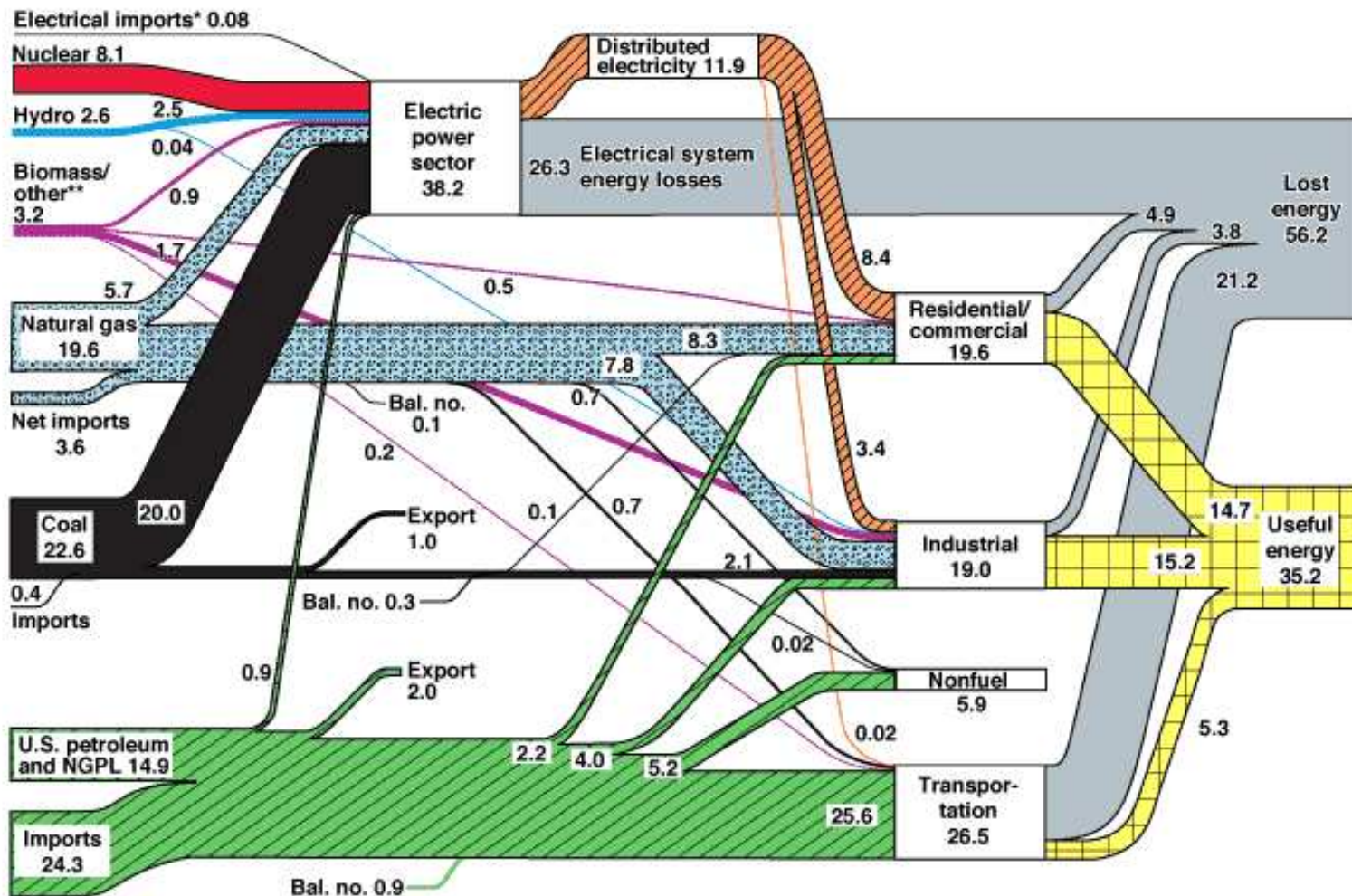

Source: Production and end-use data from Energy Information Administration, *Annual Energy Review 2002*.

*Net fossil-fuel electrical imports.

**Biomass/other includes wood, waste, alcohol, geothermal, solar, and wind.

June 2004
Lawrence Livermore
National Laboratory
<http://eed.llnl.gov/flow>

A Contemporary Technology...



Existing Grid...



Renewables Today

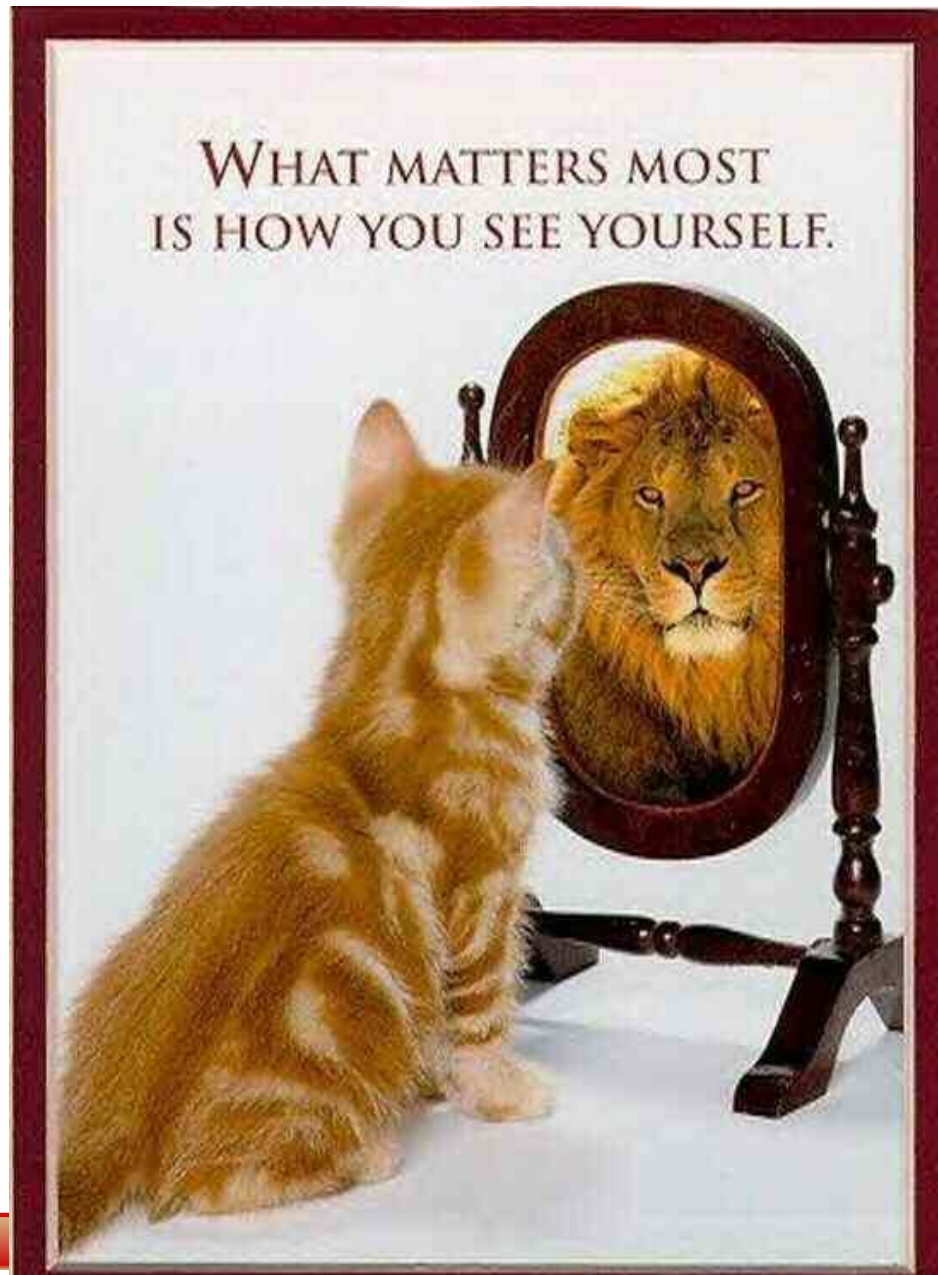

A Scenario for the Future

U.S. net energy imports

Figure 6. Total energy production and consumption, 1980-2030 (quadrillion Btu)



U.S. domestic energy production by type

Figure 7. Energy production by fuel, 1980-2030 (quadrillion Btu)

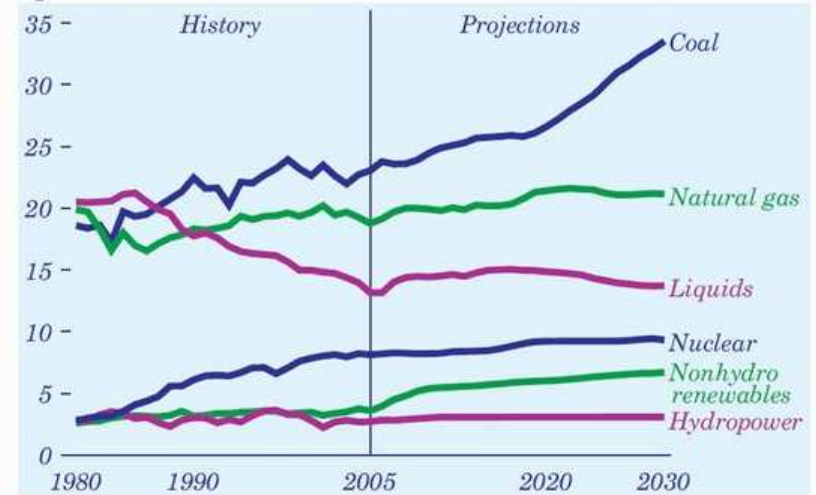

Thinking Big

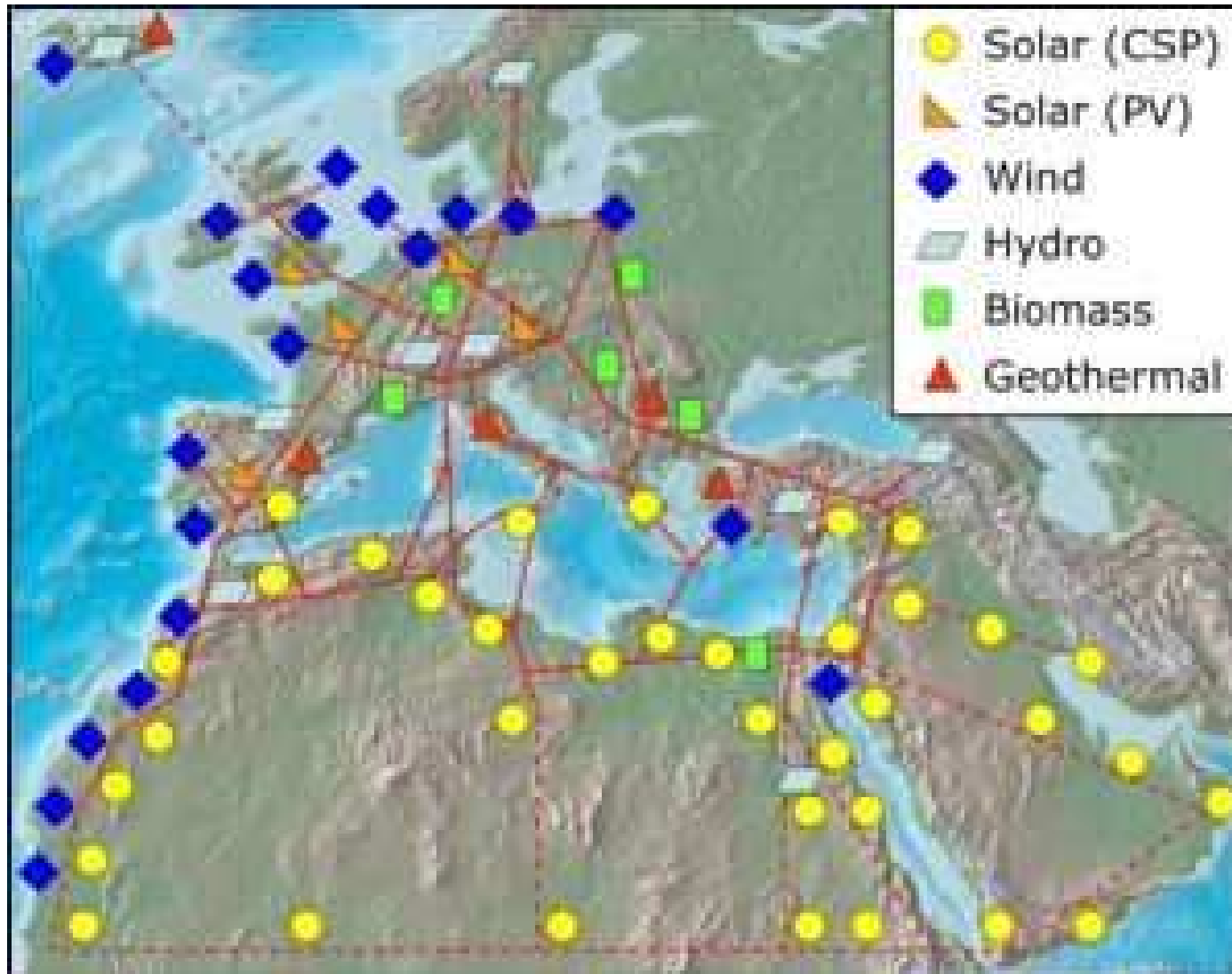

A First Glimpse - Smart Grid



System Evolution...

1900

1940

1980

2020

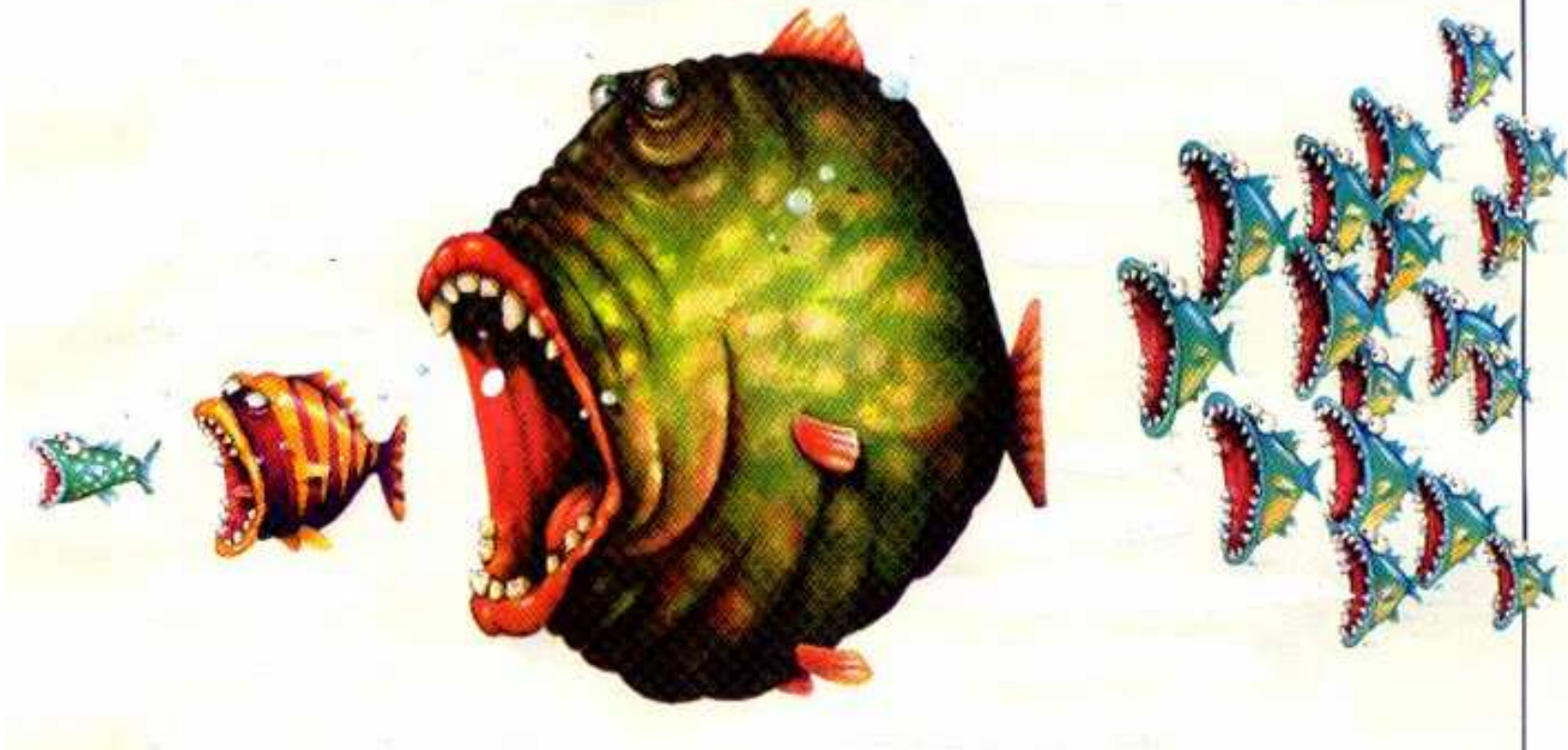

Thinking Green

UK Potential Energy Flows 2027 (TWh)

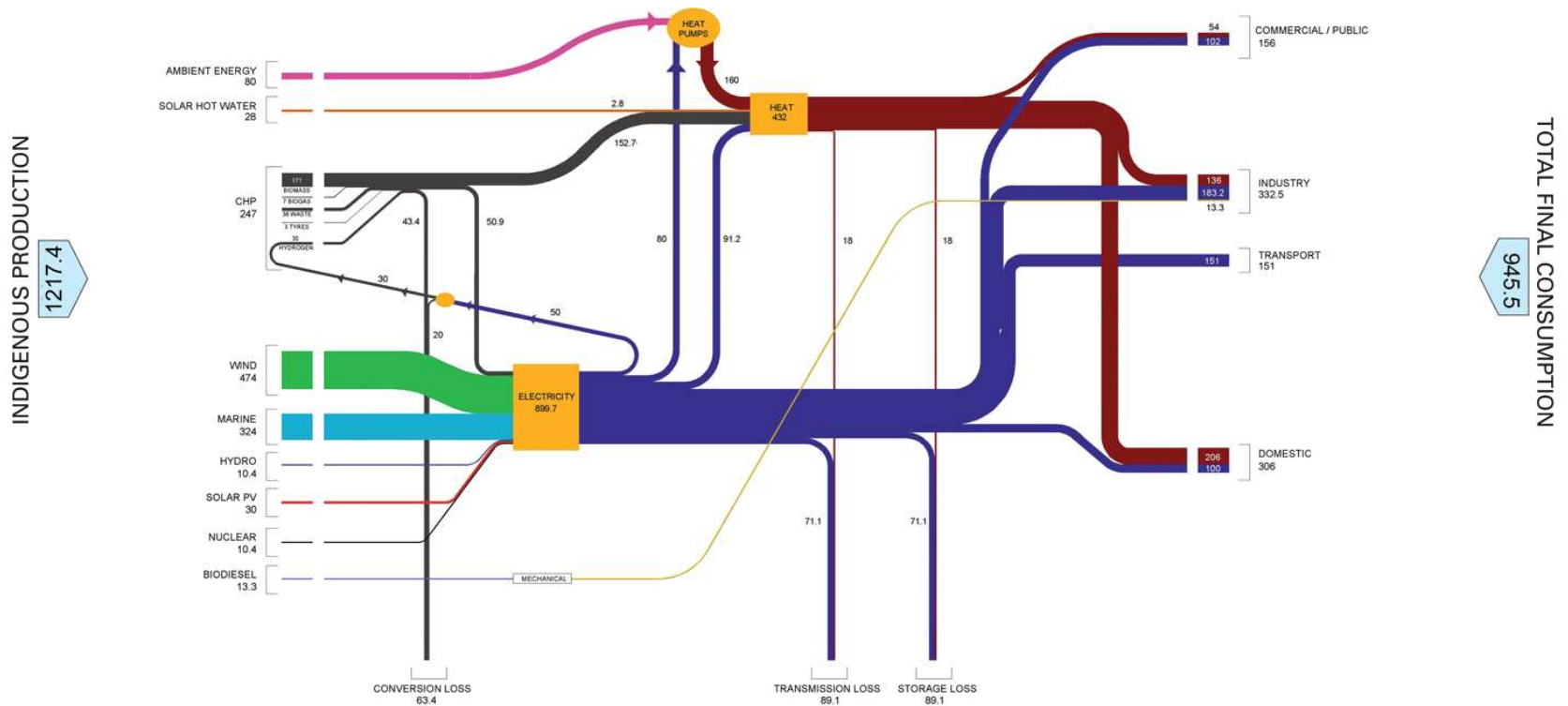
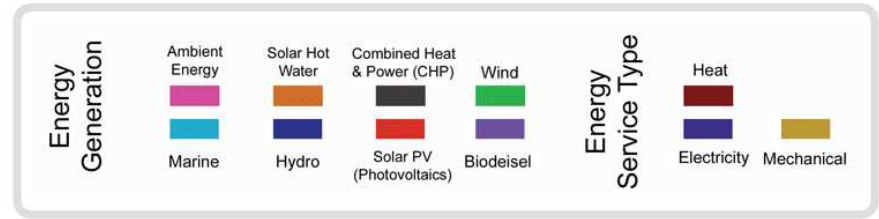

Flexible AC Transmission

Line current for 2° step changes of the firing angle:

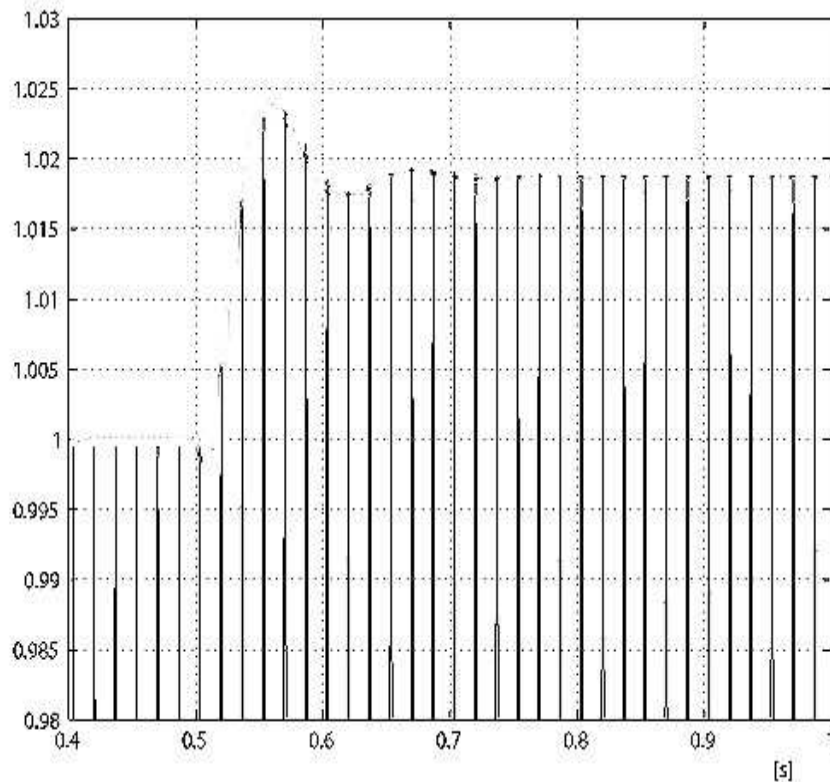

$70^\circ \rightarrow 68^\circ$

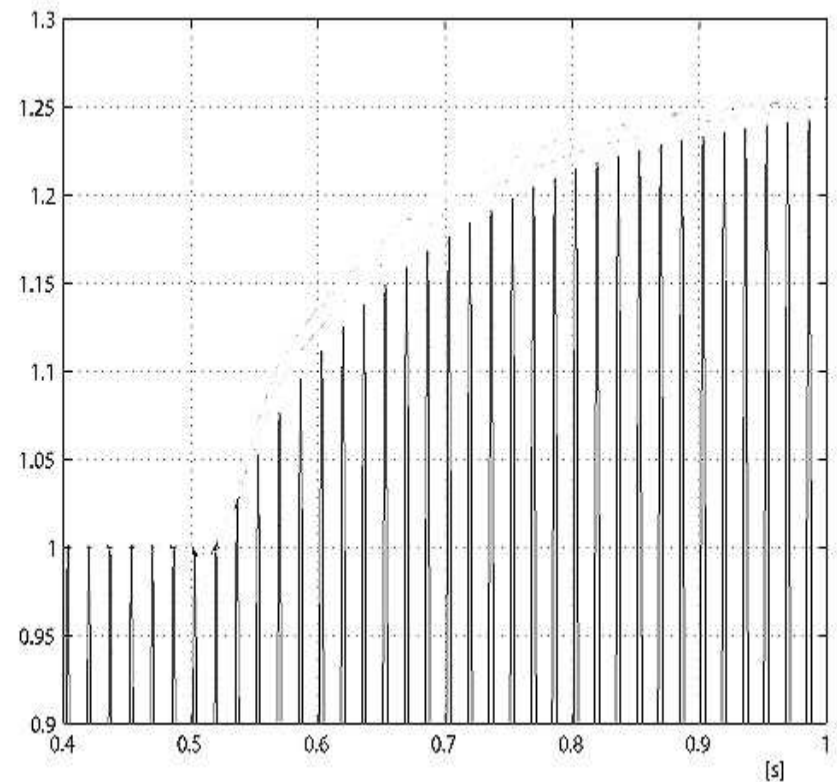

$60^\circ \rightarrow 58^\circ$

Why do we care?

Future CO2 emissions (C. Gellings):

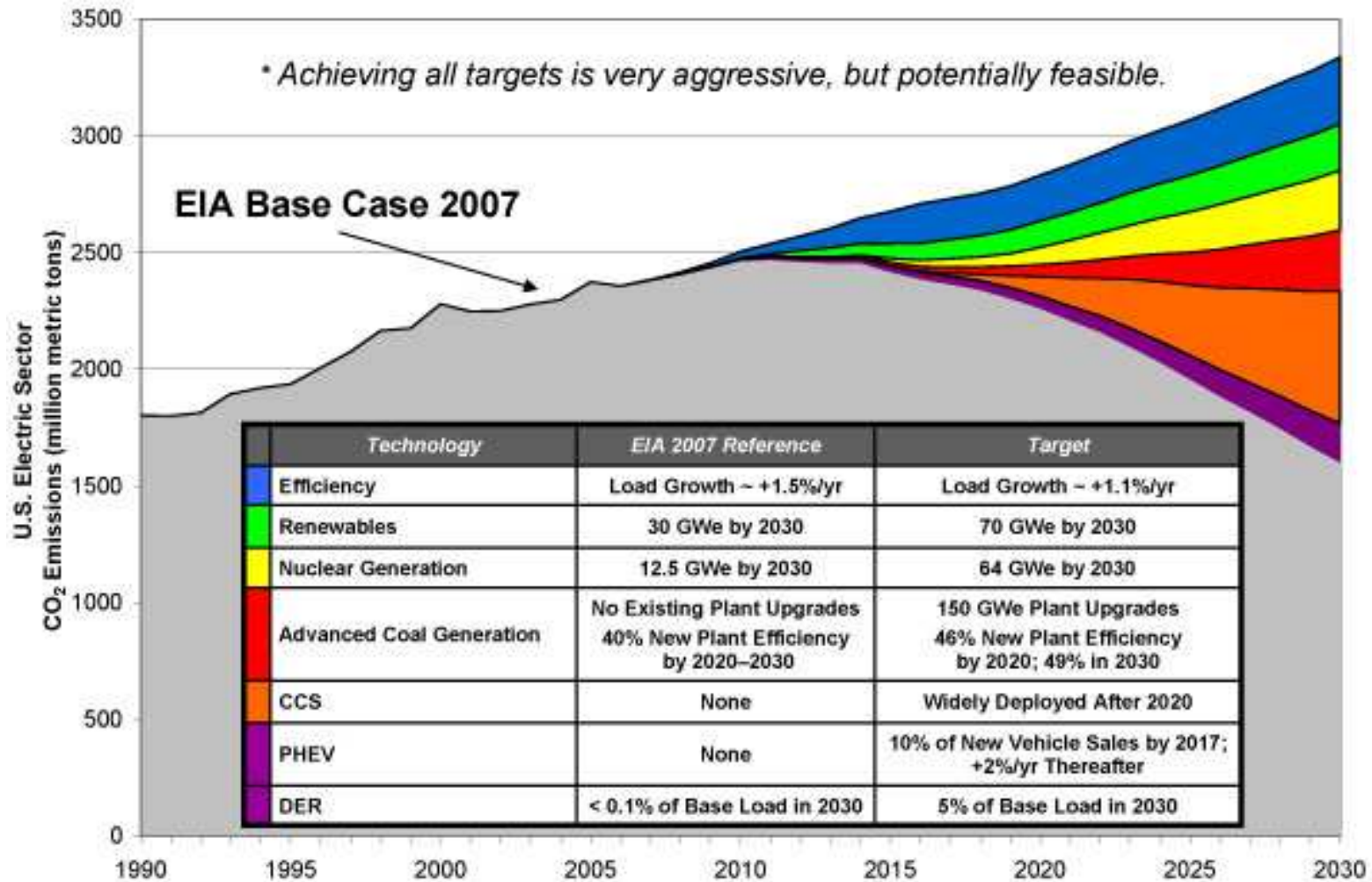

Efficiency Improvements

Potential for efficiency improvements (C. Gellings):

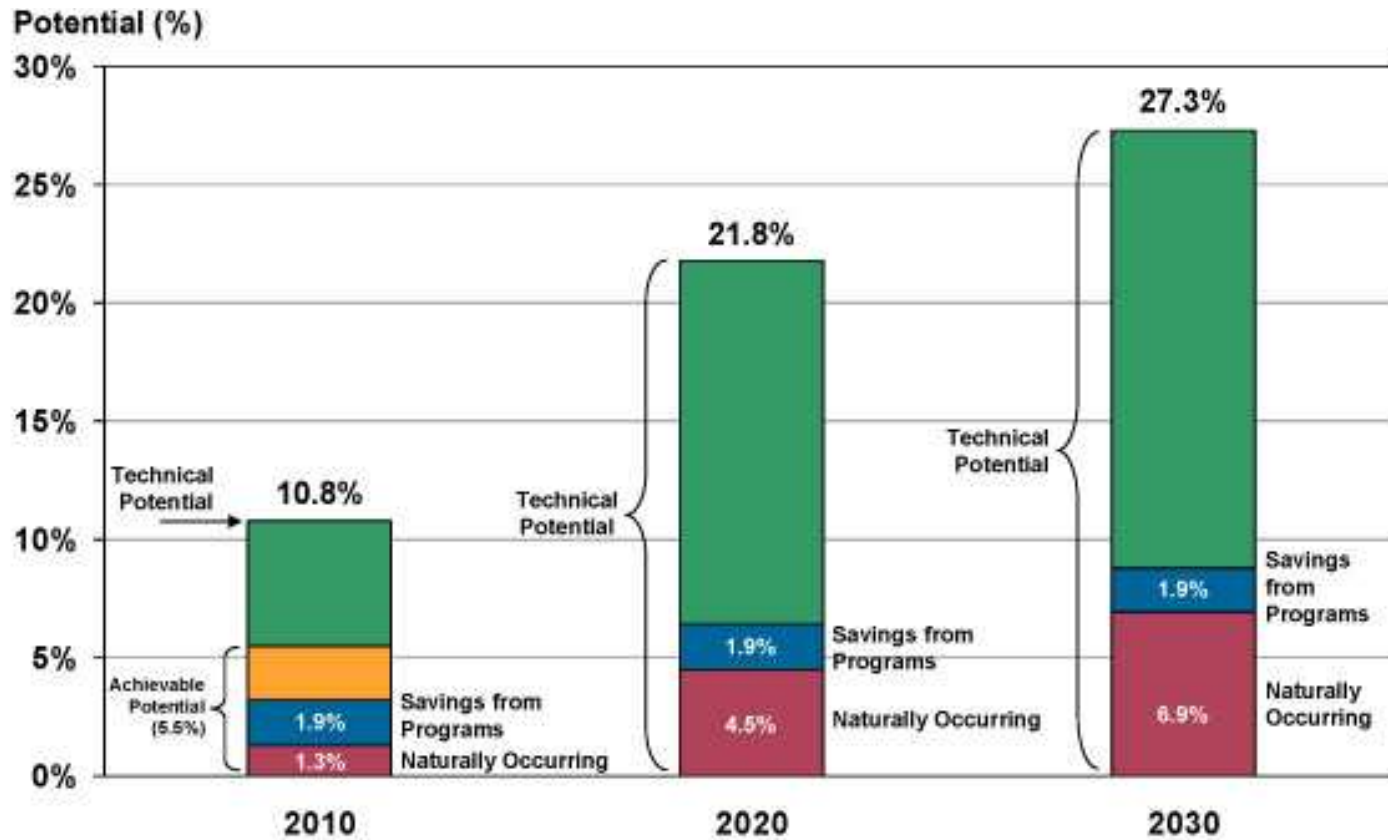

Non-Electrical Energy by Industry

Participation by industry of other forms of energy (C. Gellings):

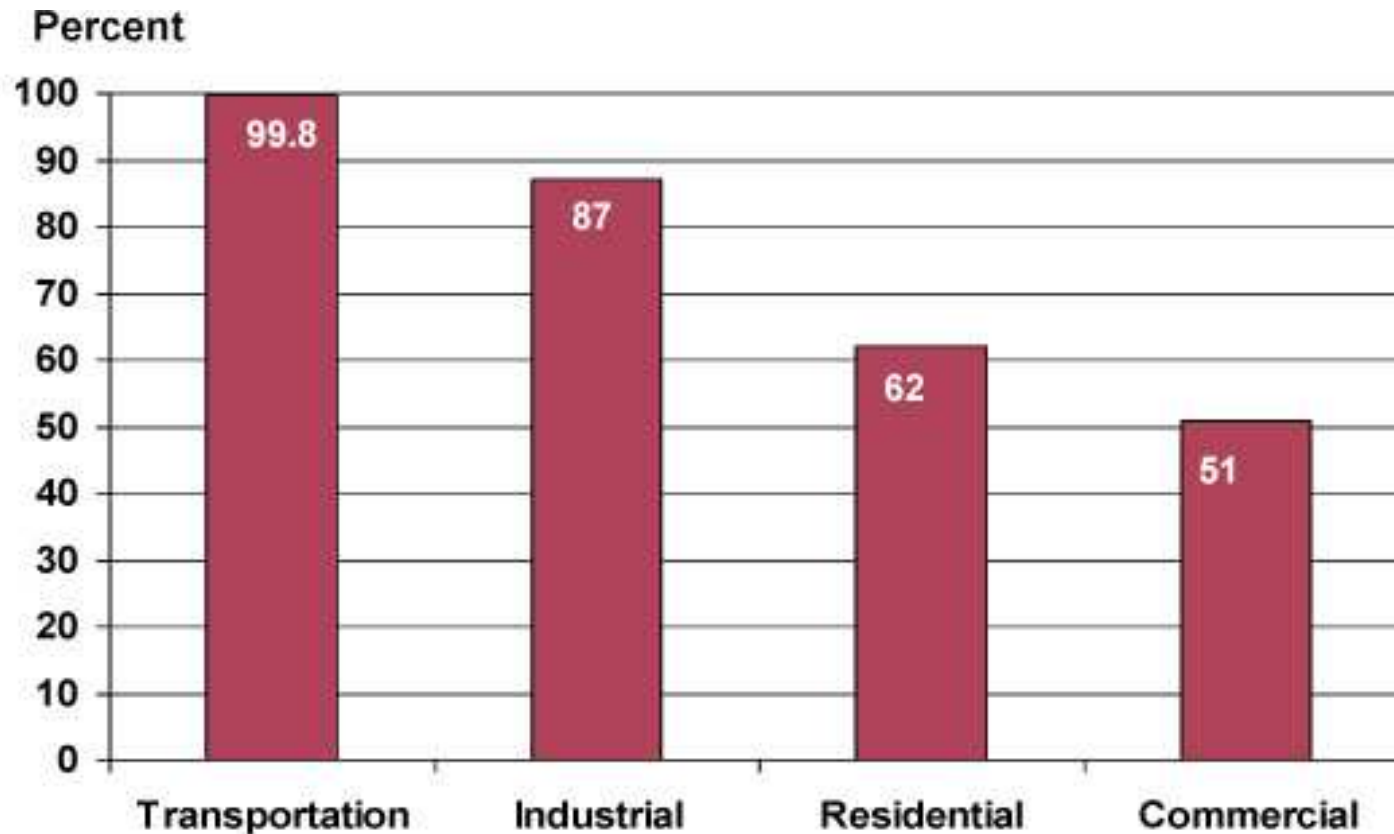

Source: DOE/EIA Annual Energy Outlook 2004.

Future Energy Needs

Change in electric energy usage (DOE, C. Gellings):

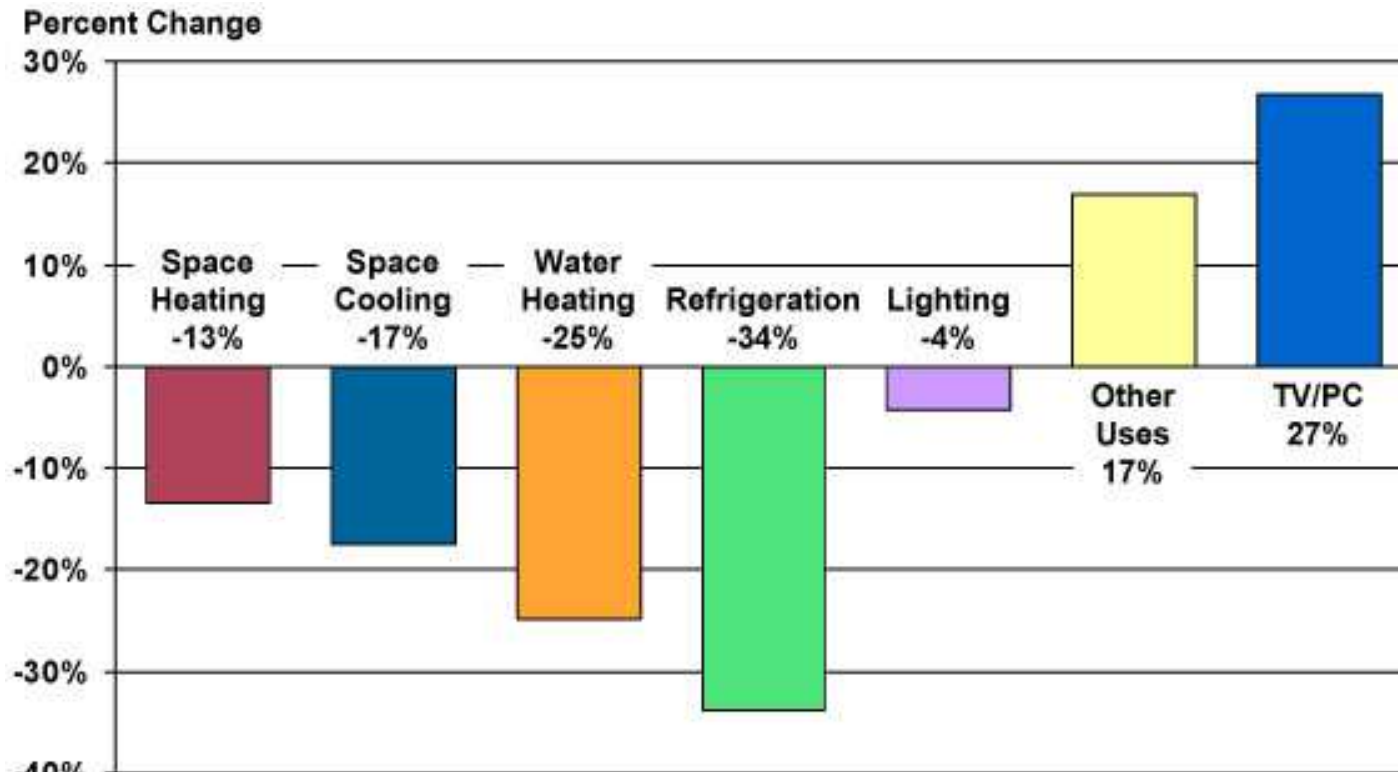

Based on: DOE/EIA Annual Energy Outlook 2007, with Projection to 2030
Heating, cooling, and lighting intensity normalized based on per sq. ft. of building space.
Refrigeration and TV/PC/set top/other uses normalized based on per household.