



MOVING TOWARDS A MORE EFFICIENT USE OF ENERGY

April 2009

Alex M. Stanković
Northeastern University, Boston

astankov@ece.neu.edu

90% of U.S. Electricity Today



Environmental Effects



Presentation Map

- Energy as a **Systems** Issue,
- Electricity as the Integration Medium,
- Energy Systems - Past & Present,
- Energy Systems - a Possible Future,
- A Role for the NU Family

Overall Energy Flows

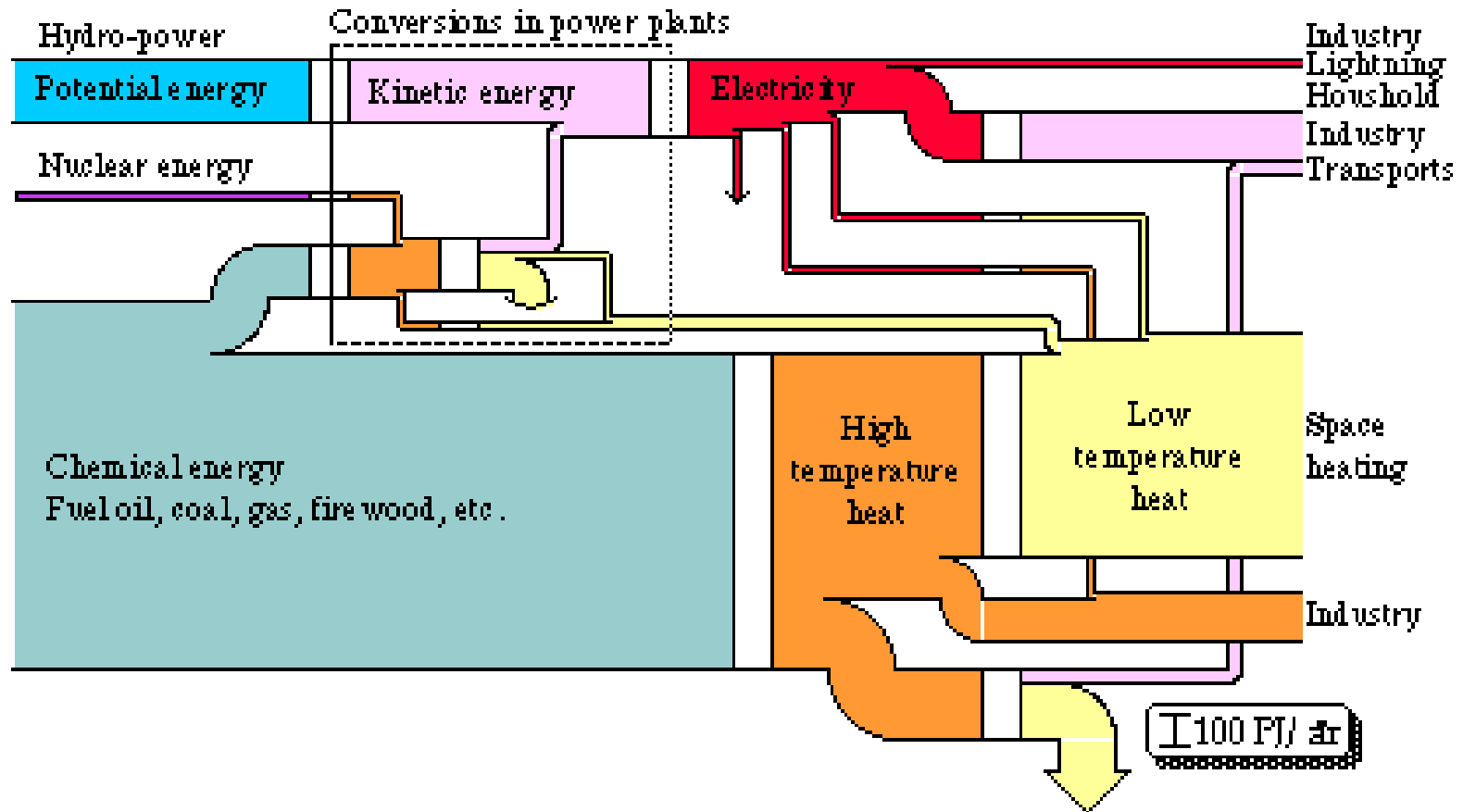

Energy Flows in the U.S.

U.S. Energy Flow Trends – 2002 Net Primary Resource Consumption ~97 Quads

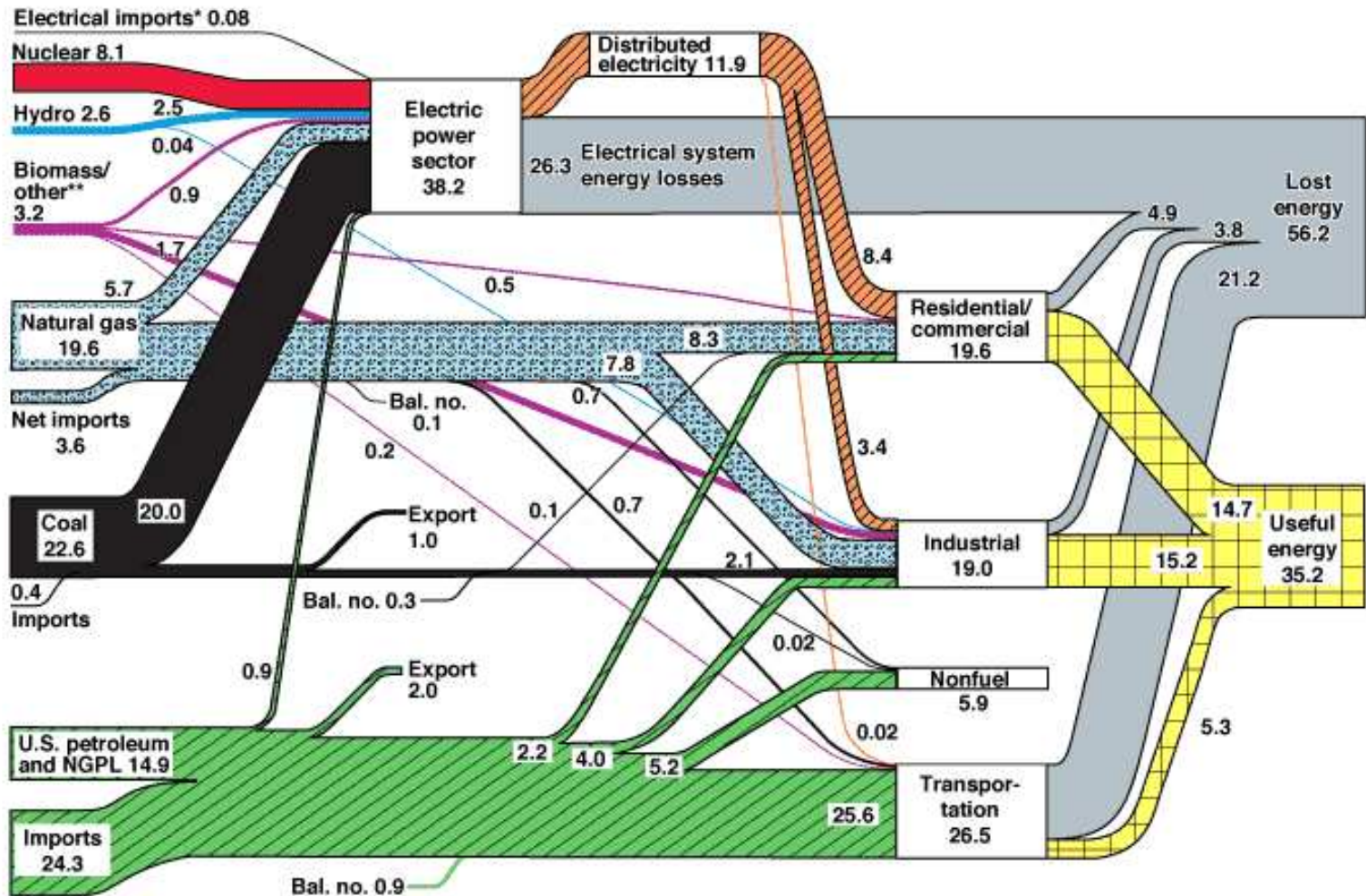

Source: Production and end-use data from Energy Information Administration, *Annual Energy Review 2002*.

*Net fossil-fuel electrical imports.

**Biomass/other includes wood, waste, alcohol, geothermal, solar, and wind.

June 2004
Lawrence Livermore
National Laboratory
<http://eed.llnl.gov/flow>

Presentation Map

- Energy as a Systems Issue,
- Electricity as the Integration Medium,
- Energy Systems - Past & Present,
- Energy Systems - a Possible Future,
- A Role for the NU Family

Why Electric Energy Systems?

Systems aim to achieve level **reliability** that far exceeds the reliability of individual components, through corrections of control actions based on **evaluating or sensing** its current state.

Why Electric Energy Systems?

Systems aim to achieve level **reliability** that far exceeds the reliability of individual components, through corrections of control actions based on **evaluating or sensing** its current state.

Examples of energy system reliability targets:

Reliability %	N "nines"	Down time
99.9	3	9 hr/yr
99.999	5	5 min/yr
99.99999	7	3 sec/yr
99.9999999	9	2 cycles/yr

Why Electric Energy Systems?

Systems aim to achieve level **reliability** that far exceeds the reliability of individual components, through corrections of control actions based on **evaluating or sensing** its current state.

Examples of energy system reliability targets:

Reliability %	N "nines"	Down time
99.9	3	9 hr/yr
99.999	5	5 min/yr
99.99999	7	3 sec/yr
99.9999999	9	2 cycles/yr

Events from real life (G.T. Heydt):

Losing in roulette	N=1.6
Losing the PowerBall lottery	N=6
FAA design for aircraft	N=9-12

Electricity in the U.S.

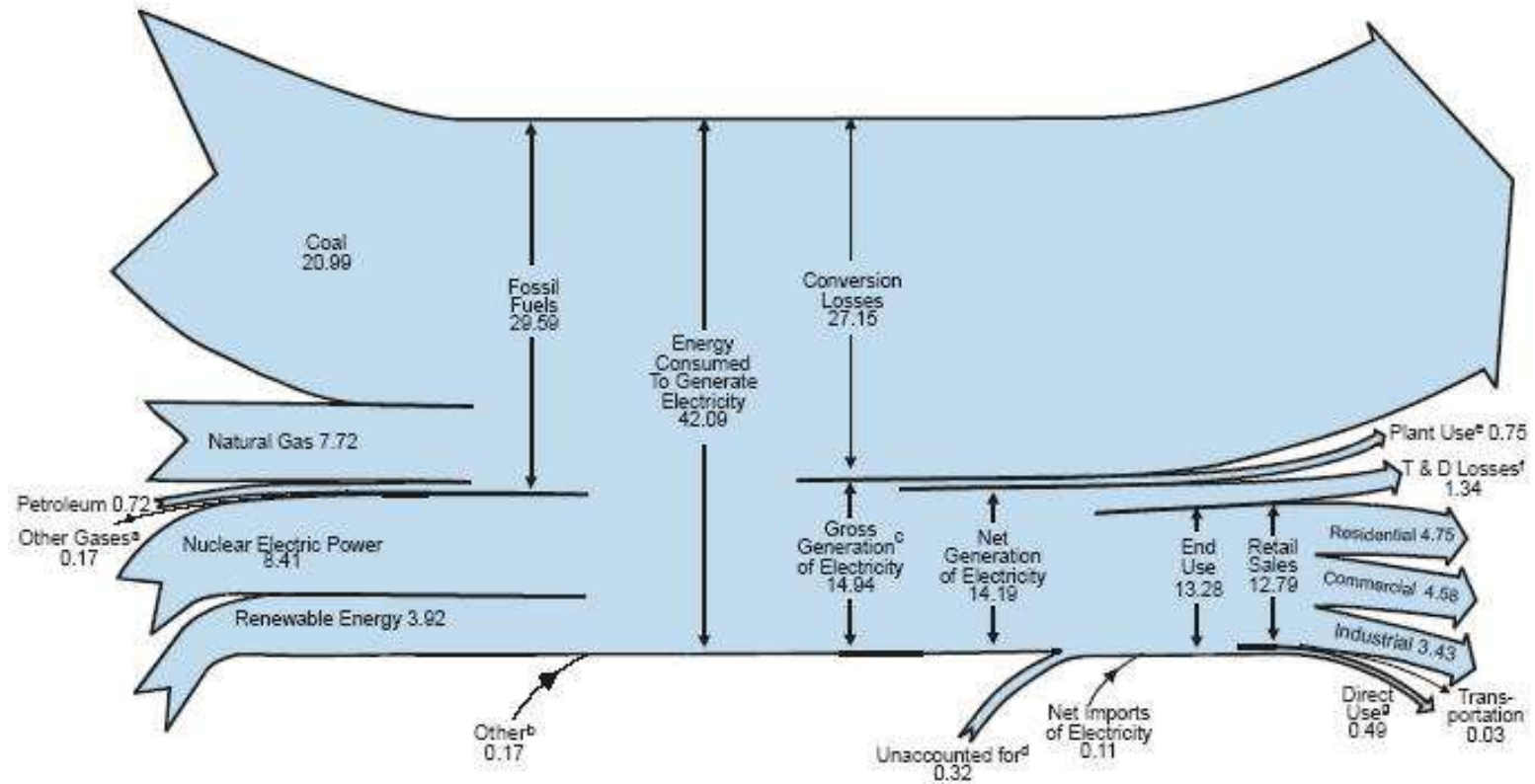

Characteristics of Electric Energy Network

- Built for **efficiency**.
- **Multi-scale** in time (>10 orders of magnitude), space (>7 orders of magnitude) and by power flow (>10 orders of magnitude).
- **Hybrid** - continuous and discrete acting components.
- **Normal** and **faulted** operation (nature and human adversaries).

Characteristics of Electric Energy Network

- Built for **efficiency**.
- **Multi-scale** in time (>10 orders of magnitude), space (>7 orders of magnitude) and by power flow (>10 orders of magnitude).
- **Hybrid** - continuous and discrete acting components.
- **Normal** and **faulted** operation (nature and human adversaries).
- Two main layers - **energy** and **information** flow.
- Limited actuation.
- **Uncertainty** (epistemic and aleatory).
- Input/Output characteristics are **regularized** by physics (conservation laws, coherences and invariants).

Cascading Faults

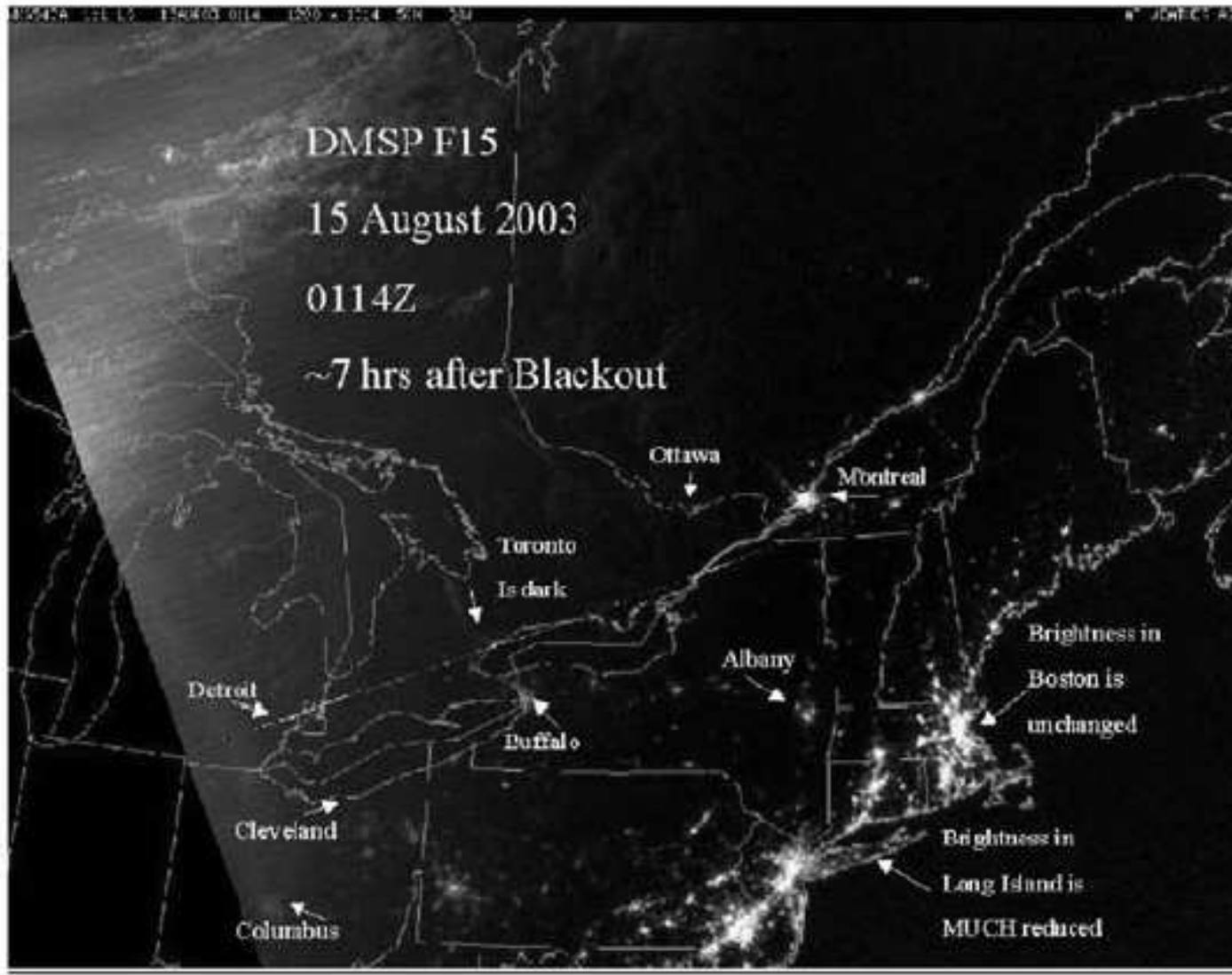

Presentation Map

- Energy as a Systems Issue,
- Electricity as the Integration Medium,
- Energy Systems - Past & Present,
- Energy Systems - a Possible Future,
- A Role for the NU Family

A Contemporary Technology...



Existing Grid...



Existing Energy Systems

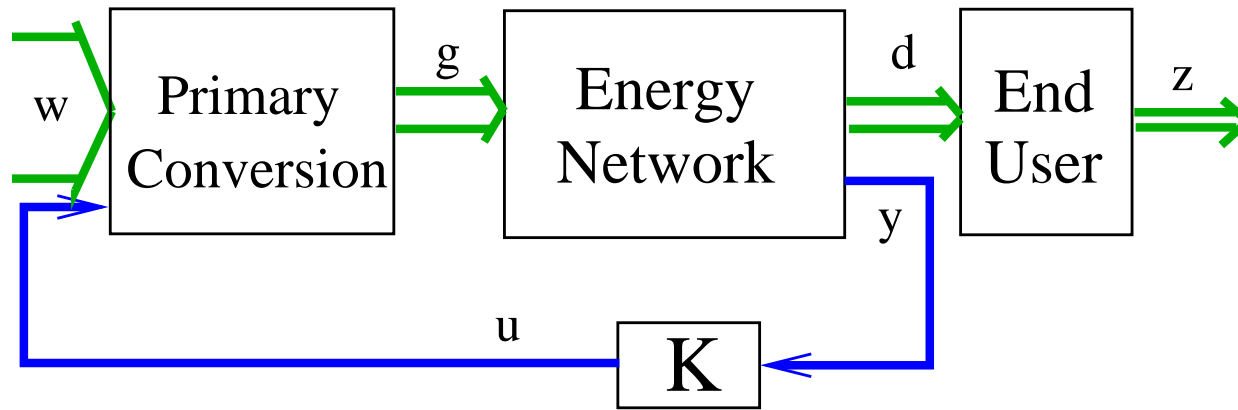

Existing Energy Systems

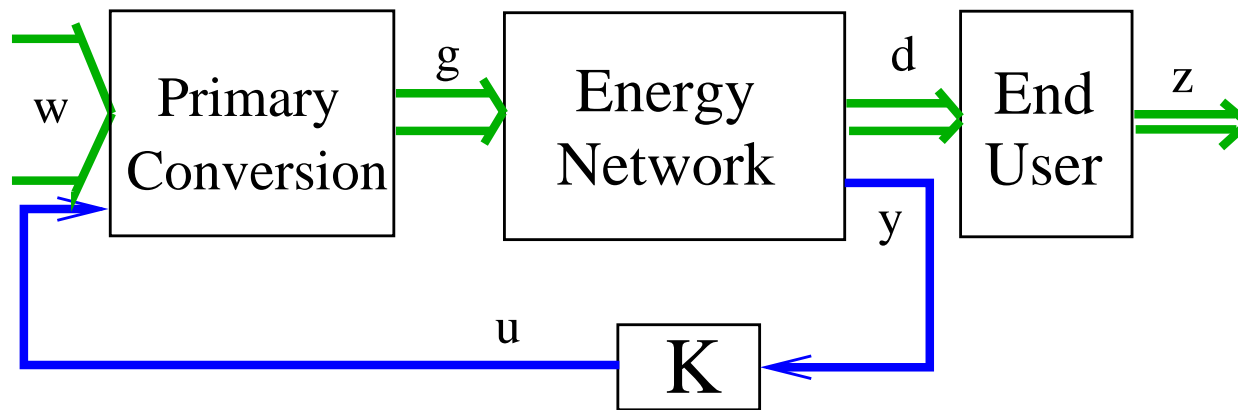

- w too large, little from renewables,
- Unable to integrate novel components,
- Non-functional markets,
- Over-designed components - variations in z ,
- Over-designed components - fault accommodation,
- Cascading faults.

Presentation Map

- Energy as a Systems Issue,
- Electricity as the Integration Medium,
- Energy Systems - Past & Present,
- Energy Systems - a Possible Future,
- A Role for the NU Family

Future Energy Systems VLSIE

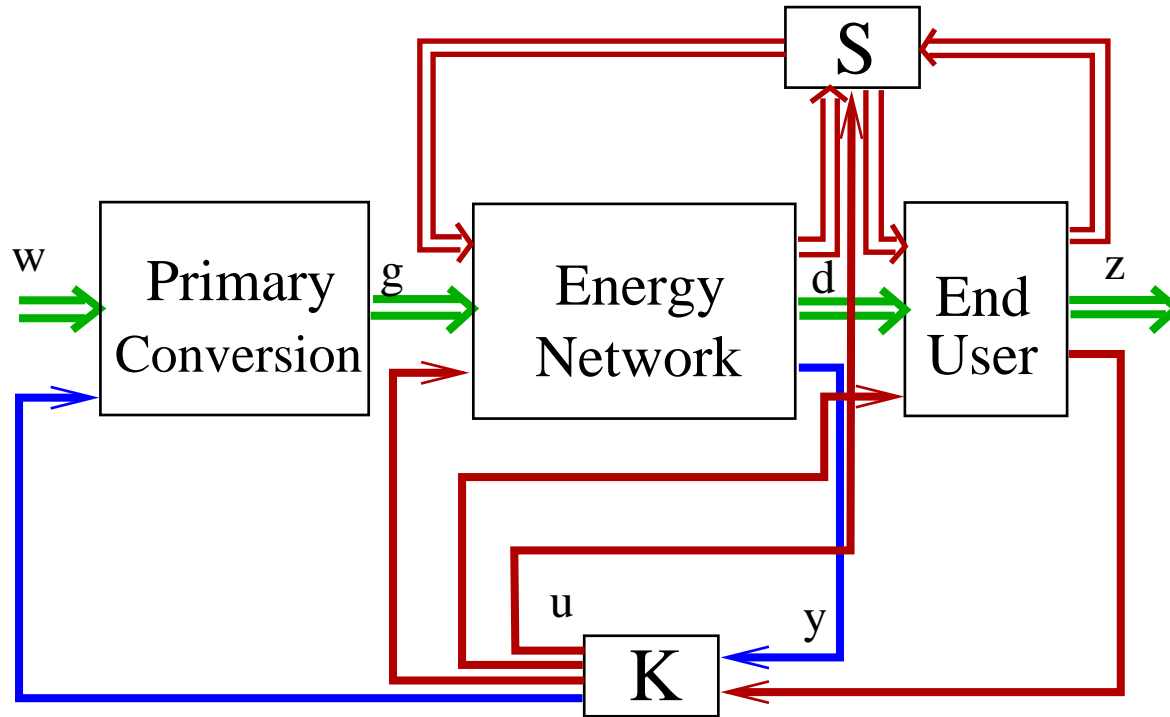

Future Energy Systems VLSIE

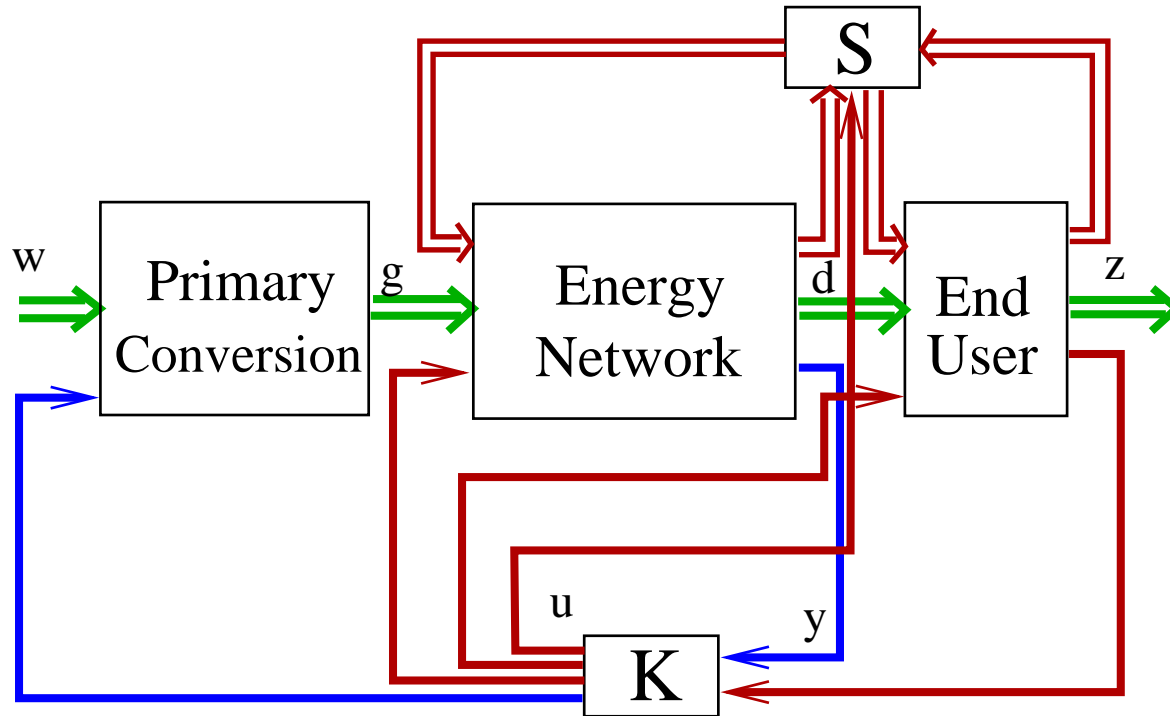

- **Information layer**
 (sensors, coordinated K = local + global context, loads inside)
- **Better blocks,**
- **More w from renewables,**

- **Flatter control** - decoupling from above and below, faster, more authority via storage and routing,
- **Better design** while steering component development.

Renewables Today

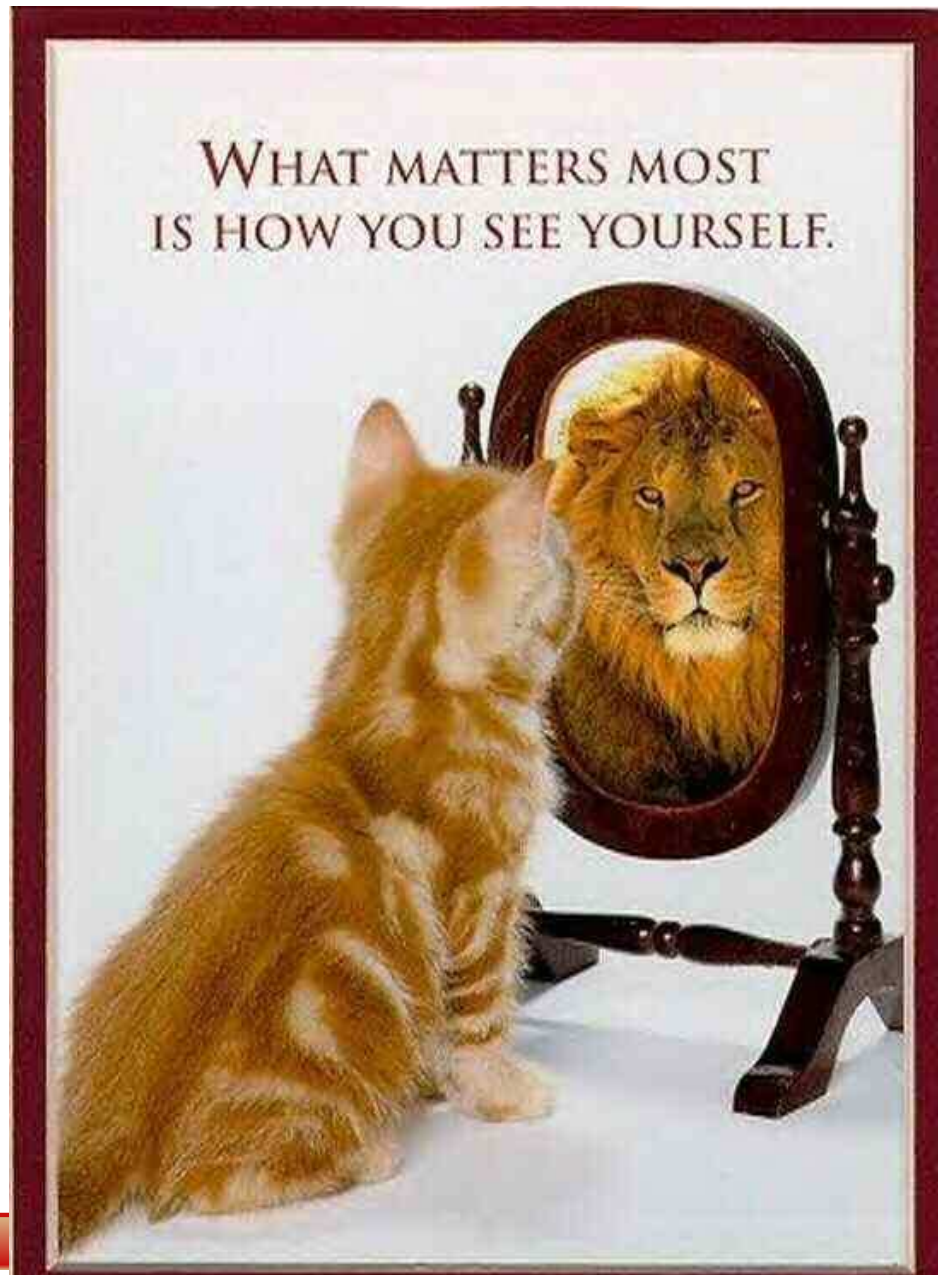

A Scenario for the Future

U.S. net energy imports

Figure 6. Total energy production and consumption, 1980-2030 (quadrillion Btu)



U.S. domestic energy production by type

Figure 7. Energy production by fuel, 1980-2030 (quadrillion Btu)

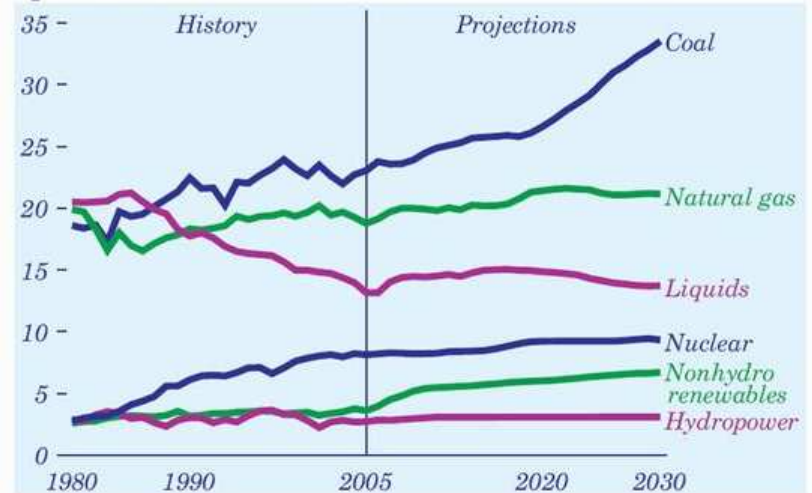

Thinking Big

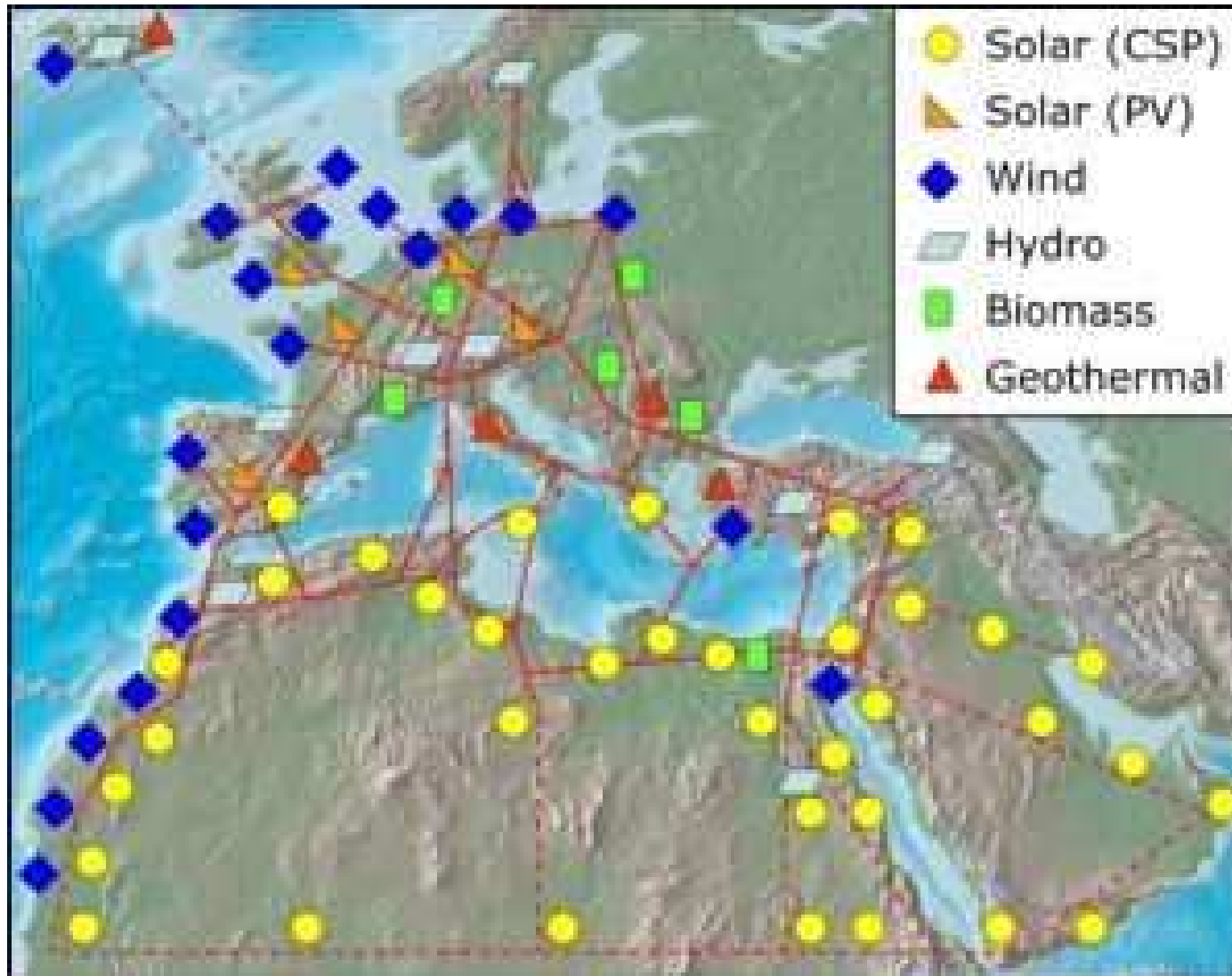

A First Glimpse - Smart Grid



Presentation Map

- Energy as a Systems Issue,
- Electricity as the Integration Medium,
- Energy Systems - Past & Present,
- Energy Systems - a Possible Future,
- A Role for the NU Family

Getting there...

- Northeastern University has maintained and expanded energy programs in engineering **despite** the “common wisdom”.

Getting there...

- Northeastern University has maintained and expanded energy programs in engineering **despite** the “common wisdom”.
- Society expects 1) carbon-free electricity, 2) networks resilient to outages, and 3) functional markets and public policy.

Getting there...

- Northeastern University has maintained and expanded energy programs in engineering **despite** the “common wisdom”.
- Society expects 1) carbon-free electricity, 2) networks resilient to outages, and 3) functional markets and public policy.
Transition:
- The efficiency is determined by the energy flow layer,
- **Key enablers** for improvement are in the information flow layer,
- The trajectory to future energy systems will be economy and policy driven (e.g., energy levels for sensors vs. storage).

Getting there...

- Northeastern University has maintained and expanded energy programs in engineering **despite** the “common wisdom”.
- Society expects 1) carbon-free electricity, 2) networks resilient to outages, and 3) functional markets and public policy.
Transition:
- The efficiency is determined by the energy flow layer,
- **Key enablers** for improvement are in the information flow layer,
- The trajectory to future energy systems will be economy and policy driven (e.g., energy levels for sensors vs. storage).
- Our future - existing and **new** research centers,

Getting there...

- Northeastern University has maintained and expanded energy programs in engineering **despite** the “common wisdom”.
- Society expects 1) carbon-free electricity, 2) networks resilient to outages, and 3) functional markets and public policy.
Transition:
- The efficiency is determined by the energy flow layer,
- **Key enablers** for improvement are in the information flow layer,
- The trajectory to future energy systems will be economy and policy driven (e.g., energy levels for sensors vs. storage).
- Our future - existing and **new** research centers,
- “The energy crisis appears to me to be more a crisis of momentum than of energy – a crisis of enterprise, solidarity, common spirit, determination and cooperation for the common good.” - Ulam

ACKNOWLEDGMENTS

My heartfelt thanks to many colleagues and former students consulted about energy systems: M. Amin, G. Andersson, T. Aydin, M. Begovic, D. Boroyevich, C. DeMarco, I. Dobson, G. Escobar, J. Hauer, D. Hill, M. Ilic, C. Jacobson, I. Kamwa, J. Kolar, P. Kokotovic, B. Krogh, J. Lang, H. Lev-Ari, P.-A. Lof, N. Martins, P. Mattavelli, M. Morari, M.A. Pai, M. Perisic, R. Ortega, N. Rau, J. Sanchez-Gasca, A. Saric, P. Sauer, S. Sanders, A. Sangiovanni-Vincentelli, D. Siljak, C. Taylor, G. Verghese, F. Wu.

Contact info:

astankov@ece.neu.edu

www.ece.neu.edu/faculty/stankovic

System Evolution...

1900

1940

1980

2020

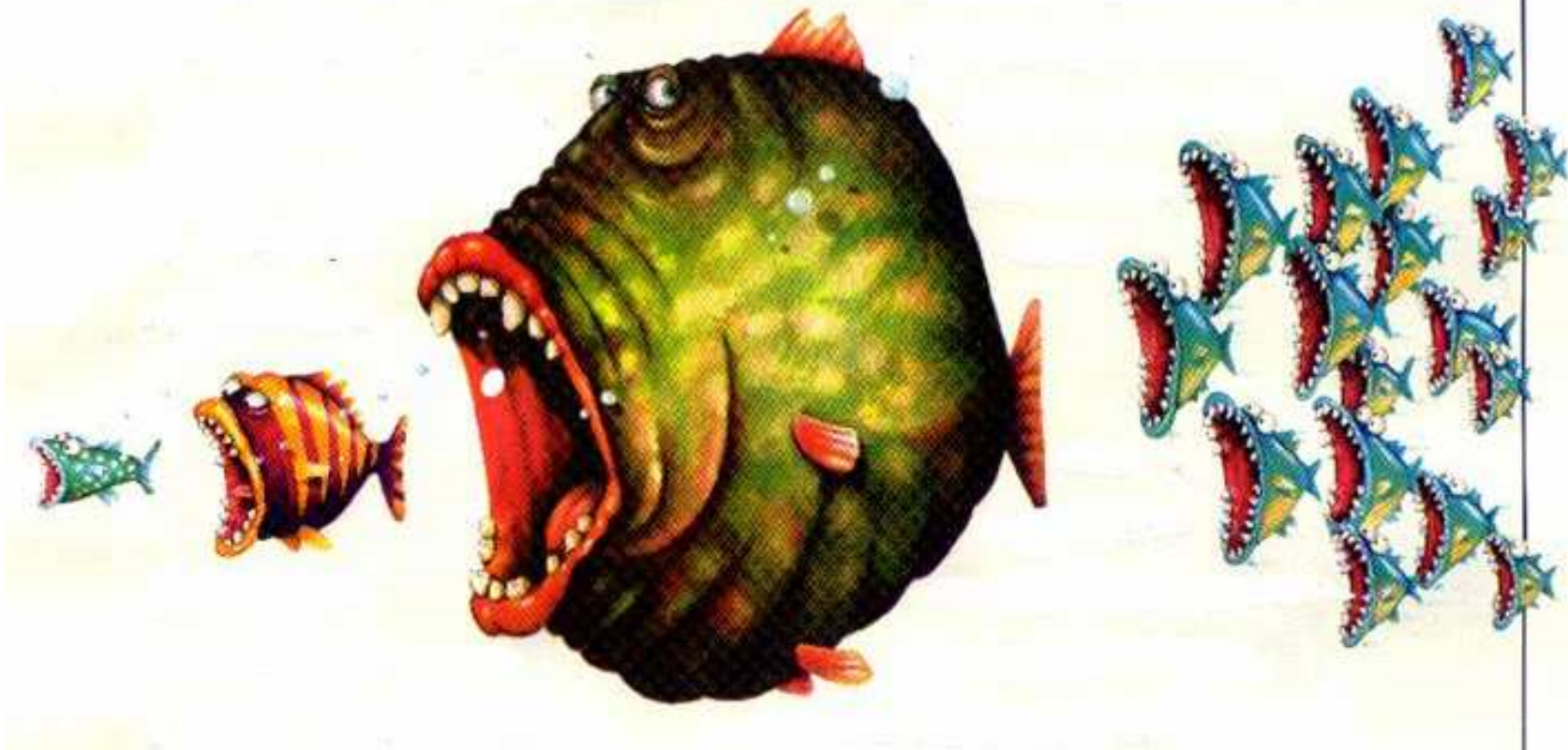

Thinking Green

UK Potential Energy Flows 2027 (TWh)

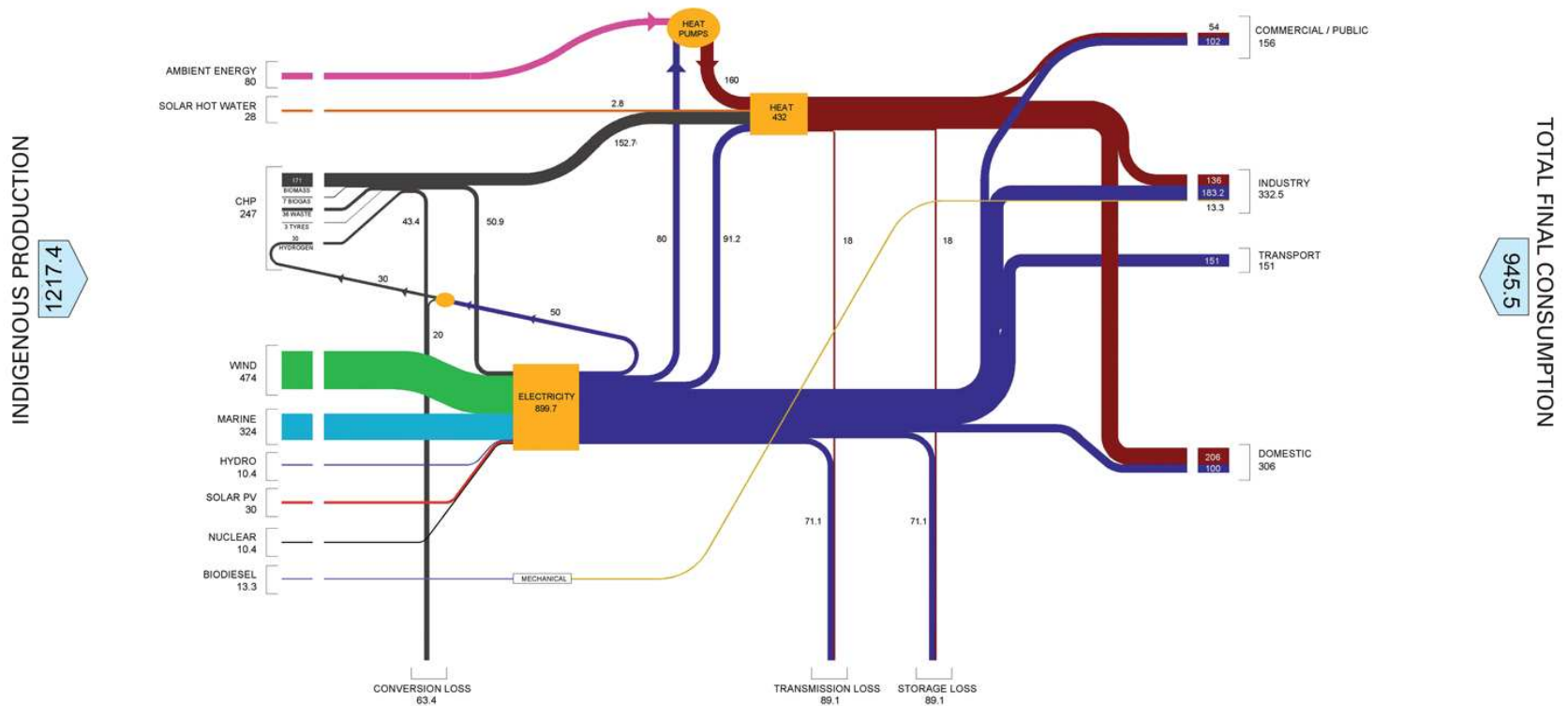
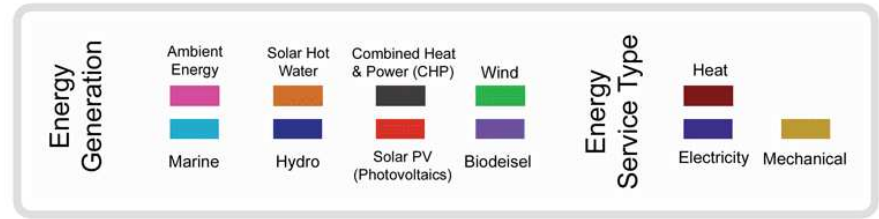

NAE Grand Challenges

14 grand challenges for engineering in the 21-st century (Feb. 2008):

- 1. Environmentally friendly power.
- 2. Nuclear fusion.
- 3. Carbon dioxide sequestration.
- 6. Sustaining the aging infrastructure.

NAE Grand Challenges

14 grand challenges for engineering in the 21-st century (Feb. 2008):

- 1. Environmentally friendly power.
- 2. Nuclear fusion.
- 3. Carbon dioxide sequestration.
- 6. Sustaining the aging infrastructure.

A **recurring theme**: “The vast networks of electrification are the greatest engineering achievement of the 20-th century.”