

A Comparative Performance Evaluation of Wake-up Radio-based Data Forwarding for Green Wireless Networks

Stefano Basagni^{*}, Georgia Koutsandria[†], Chiara Petrioli[†]

^{*} ECE Dept., Northeastern University, Boston, MA

Email: basagni@ece.neu.edu

[†] Computer Science Department, University of Rome “La Sapienza,” Rome, Italy

Email: {koutsandria, petrioli}@di.uniroma1.it

Abstract—The advent of low-power sensor nodes coupled with intelligent software and hardware technologies has led to the era of *green wireless networks*. From the hardware perspective, green sensor nodes are endowed with energy scavenging capabilities to overcome energy-related limitations. They are also endowed with low-power triggering techniques, i.e., wake-up radios, to eliminate idle listening-induced communication costs. In this paper, we present a comparative performance evaluation of three different data forwarding strategies for green wireless networks, namely, CTP-WUR, GREENROUTES, and WHARP, which have been shown to outperform previous state-of-art solutions. Through GreenCastalia-based simulations we analyze and provide insights into the impact on performance of diverse forwarding design choices, ranging from traditional tree-based routing (CTP-WUR), to end-to-end energy-driven route selection (GREENROUTES), to the use of sophisticated learning models (WHARP). Results show that tree-based routing obtains lesser packet delivery ratio than WHARP, thus indicating that including energy harvesting awareness in route selection results in performance advantages. However, the proactive nature of route computation of CTP-WUR results in faster packet delivery and lower energy consumption, requesting further optimization of the cross-layer forwarding of GREENROUTES and WHARP.

I. INTRODUCTION

The operational lifetime of wireless sensor networked systems where nodes are battery-operated provides the evidence of their fundamental limitation. All the long term applications enabled by these systems, including surveillance and monitoring, suffer from premature energy depletion, emphasizing the need of energy-efficient hardware and software solutions. As a consequence, in recent years the notion of self-sustainable wireless sensor networks (WSNs) has been gaining rapid growth due to their beneficial feature of tackling the dominant energy-related limitations [1], [2], [3]. In these networks operations can be sustained by the energy harvested from the environment, such as sun, wind and other sources [4], [5].

Although nodes in energy harvesting-based WSNs have the potential of boundless lifetime, the uncertainty of the energy harvesting rates makes them susceptible to unpredictable operational “black outs:” When a node depletes its energy, it cannot longer function; once it harvests sufficient energy to perform its tasks, it becomes operational again. Clearly, the shorter the black outs, the better the network performance. For this reason,

all possible sources of useless energy consumption should be reduced to a minimum, which includes a node idly listening to the wireless channel awaiting for incoming transmissions. To obviate to idle listening, research has proposed low-power triggering techniques aimed at leaving nodes with their radio off until they need to receive data. Particularly, a node that is ready to forward packets uses a low power transducer to *wake up* selected neighbors, among which a relay will be chosen to advance the packet towards its final destination (the network *sink*). Recent proposals have provided wake-up radio receivers whose energy consumption is up to three order of magnitude lower than that of the node main radio. This provides savings comparable to nodes in low power mode (sleep mode—“main radio off;” energy consumption in the μ Watts), while avoiding the latency typical of duty cycle-based solutions [6], [7]. Furthermore, wake-up sequences can be selected to wake up nodes depending on their current status (rather than, simply, their own ID), thus allowing designers to implement sophisticated relay selection techniques (semantic awakenings [6], [8]).

This paper concerns the comparative investigation of the performance of three data forwarding strategies in wireless sensor networks whose nodes are capable of energy harvesting and feature low power wake-up radios. We call these networks *green wireless networks*. We are concerned with recently proposed solutions that have been designed to take full advantage of both technologies of green networking, namely, energy harvesting and wake-up radios with semantic awakenings. In particular, our investigation is aimed at providing insights about different forwarding design choices and their consequences on network performance.

The first forwarding strategy, named CTP-WUR [9], is built upon the Collection Tree Protocol (CTP) [10], re-designed to take advantage of wake-up receivers (WURs). Forwarding decisions are made by following a pre-built minimum-cost tree rooted at the sink, a somewhat classical solution for routing in WSNs. CTP-WUR takes advantage of wake-up radios by allowing the relay of wake-up requests, thus saving on main radio usage, especially for sending control packets. The other two data forwarding strategies, namely GREENROUTES

and WHARP, are both cross-layer approaches where channel access and relay selection are performed jointly according to some form of energy-awareness. In GREENROUTES next-hop selection depends on the distance of a node from the sink and on the residual energy available along recently used routes to the sink (end-to-end energy awareness) [11]. In WHARP energy prediction techniques are used jointly with a Markov Decision Process (MDP) to allow each node to decide whether to make itself available for data forwarding or not [12].¹

All three data forwarding solutions have been implemented in GreenCastalia [13], an extension to the Castalia simulator [14] that models wake-up radios and their integration to the sensor mote MagoNode++ [15] in great details. Parameters are based on experimental traces from prototypes we designed and built [16]. In scenarios with varying data traffic, we compare the three data forwarding strategies with respect to the following key performance metrics: Packet overhead, measuring the fraction of control traffic generated by each protocol, end-to-end latency of all packets successfully delivered to the sink, the total energy consumption spent by the network, and the packet delivery ratio, i.e., the percentage of data packets successfully delivered to the sink.

Our results show that in general cross-layer approaches relying on contention-based mechanisms for relay selection suffer from higher delays because of the per packet RTS/CTS-like handshakes, and incur high energy consumption as the contention itself involves waking up multiple potential next-hop relays. Proactive approaches like CTP-WUR are faster and lighter, because the next-hop relay is pre-determined. However, they show their limitation when nodes black out, which results in packet loss due to the lack of timely topology updates. Approaches that employ sophisticated learning models, like WHARP, successfully deal with nodes that run out of energy by implementing forwarding policies that penalize selection of relays on routes with nodes blacked out. We conclude also that the use of mechanisms to directly forward data packets to a known and already used next-hop relay, as in GREENROUTES and WHARP, can extremely decrease end-to-end latency. In fact, this latency is observed to be comparable to that incurred by strategies like CTP-WUR that do not require intensive use of control packets to gain channel access for data packets.

The remainder of the paper is organized as follows. In Section II we provide a summary of the operations of the data forwarding strategies compared in this work. Section III presents and discusses the comparative performance evaluation results. Related works are summarized in Section IV. Finally, Section V concludes the work.

¹ To the best of our knowledge, there are no other solutions explicitly designed for green wireless networks as defined in this paper, i.e., exploiting both energy harvesting and wake-up radios. Performance comparisons with data forwarding for WSNs with no energy harvesting and/or no wake-up radio capabilities would be scarcely informative [11], [12].

II. DATA FORWARDING STRATEGIES FOR GREEN WIRELESS NETWORKS

This section provides a summary of the three forwarding strategies considered in this paper. The three solutions are described for green wireless networks made up of sensor nodes that are statically deployed and that can communicate wirelessly. Data packets may reach their final destination (the sink) through several nodes, i.e., routes can be multi-hop. Each sensor node is equipped with a pair of transceivers: 1) The main radio used for control and data packets, and 2) the wake-up radio used for waking up neighboring nodes to eventually select the next-hop relay for the data packet. Nodes are provided with at least one wake-up address, which is a binary sequence whose meaning depends on the design specifications of the forwarding strategy. Wake-up addresses can be updated in time, depending on nodes status and network dynamics.

A. CTP-WUR

CTP-WUR [9] is a wake-up radio-based data forwarding strategy built upon the widely used Collection Tree Protocol (CTP) [10]. The latter, as the name suggests, delivers data to the sink by building a tree structure that provides pre-determined routes for the data packets. CTP-WUR takes advantage of the tree-based routes for relaying wake-up sequences through intermediate nodes, so to wake up the grandparent of the sender node. The intermediate node, i.e., the parent of the sender, is only responsible of relaying to the next-hop (the grandparent) the wake-up sequence without activating its main radio. Then, a sender node can transmit the data packet directly to the grandparent, saving considerable energy. The wake-up addressing mechanism of CTP-WUR requires each node to be given two addresses: 1) A broadcast wake-up address for activating its main radio when a control packet needs to be transmitted (this is used to broadcast beacons for updating the network topology tree in time), and 2) a wake-up address that consists of its unique identifier (for unicast routing). An example of the CTP-WUR forwarding strategy is shown in Fig. 1.

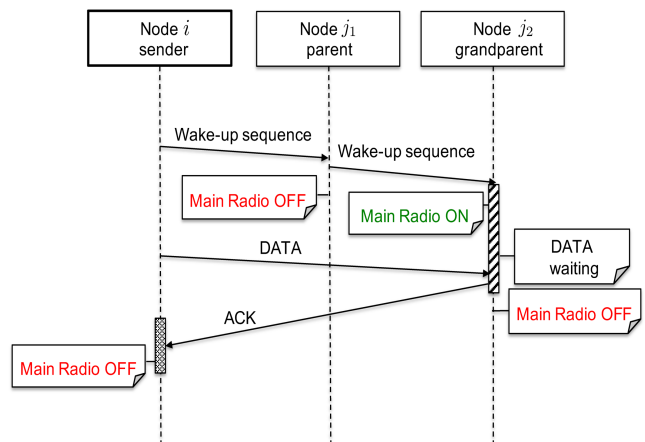

Fig. 1. CTP-WUR forwarding.

node i that are one hop closer to the sink, and therefore, they are potential next-hop relay candidates. Node i broadcasts a wake-up sequence to wake up those among them that could provide “good” forwarding to the sink. The recipients of this wake-up sequence will wake up according to the result of running an MDP that takes into account the node residual energy and a measure of the harvestable energy that will be available in the near future. In particular, the process is capable of discouraging the selection of nodes that could black out shortly. In this example, we stipulate that nodes j_1 and j_3 decide to wake up and to participate to the relay selection process. Node j_2 instead decides not to participate, ignoring the wake-up sequence. Upon reception of the wake-up sequence nodes j_1 and j_3 activate their main radio and await for an RTS packet from node i . They then compute an energy-dependent delay, and after this delay they transmit a CTS packet to node i . In this example, node j_1 transmits the CTS packet before node j_3 , thus winning the competition: It will be the recipient of the data packet. Once node j_1 receives the data packet, it replies with an ACK and switches back to sleep mode. Node i ignores any subsequent CTS packets and turns off its main radio. Node j_3 , which did not receive a packet, eventually turns off its main radio after a predefined amount of time.

III. PERFORMANCE EVALUATION

In this section we compare the performance of CTP-WUR, GREENROUTES and WHARP. We implemented all three forwarding strategies in the open-source simulator GreenCastalia [13]. GreenCastalia is an extension of the Castalia simulator [14], which models energy harvesting from heterogeneous sources, and accurately models energy-related aspects of wireless sensor networks. We further extend the capabilities of GreenCastalia to model wake-up radios and their integration to the sensor mote MagoNode++ [15] in details. Model parameters are based on experimental traces from testing of prototypes that we designed and built [16].

A. Simulation Scenarios

We consider networks with 119 nodes that are randomly and uniformly positioned in a 200m by 200m area. The sink is located at the upper right corner of the area. All nodes but the sink are equipped with on-board Sensirion SHT1x sensors to perform temperature measurements. Packets are generated as a result of sensing measurements. Measurements happen according to a Poisson process of intensity λ packets per second. In our simulations we make use of the packet inter-arrival time $1/\lambda$ ranging in the set $\{20, 15, 10, 5, 4, 3, 2, 1\}$, corresponding to traffic from low (inter-arrival time of 20s) to medium/high (1s). Once a packet is generated, a source node is randomly and uniformly chosen among the nodes. The size of the payload of each data packet is 36B. The total size of packets sent by GREENROUTES and WHARP is 58B, which adds to the payload the bytes of the headers added at different layers. CTP-WUR transmits packets whose total size is 70B. (The 12 extra bytes are needed for MAC and network layer

functions.) The transmission power of each node on the main radio is set to -2dBm , which results to a transmission range of 60m. The main radio data rate is set to 250Kbps.

The energy model considered in our experimental evaluation is based on that of the MagoNode++ mote [15]. Wake-up sequences are sent at $+10\text{dBm}$ using the low-power CC1101 transceiver from the Texas Instruments [17]. Their size is 1B. They are transmitted at 1Kbps. The power consumption of the wake-up receiver is $1.071\mu\text{W}$. Its sensitivity is -55dBm . This model also considers the power consumption of the integrated ultra-low power microcontroller (MCU) used to perform wake-up addressing, which consumes $0.036\mu\text{W}$ and $54\mu\text{W}$ in idle and active states, respectively. Half of the nodes are equipped with solar cells; the remaining nodes harvest energy using micro wind turbines. Wind and solar harvesting traces are obtained from the National Renewable Laboratory at Oak Ridge [18]. All sensor nodes store the harvested energy in a supercapacitor with maximum operating voltage of 2.3V and capacitance of 50F. We decided to use supercapacitors (as opposed to, say, rechargeable batteries) as they offer long-lasting operation lifetime while retaining a high energy capacity level when compared to battery-operated networks [19]. The supercapacitor is initially full.

B. Performance Metrics

We compare the three forwarding strategies through the investigation of the following performance metrics (all averages).

- 1) The *packet overhead*, computed as the number of bytes of control packets normalized to the number of bytes of all generated data packets.
- 2) The *latency*, computed as the time needed to successfully deliver a packet to the sink, i.e., from its generation to the time the sink receives it.
- 3) The *total network energy consumption*, defined as the total amount of energy consumed by all nodes (but the sink).
- 4) The *packet delivery ratio*, defined as the percentage of packets successfully delivered to the sink.

All results have been obtained by averaging the outcomes of a number of simulation runs large enough to obtain a 95% confidence interval with 5% precision. Simulation time is set to 5 days. In order to evaluate steady-state performance, all metrics are collected after the initial network setup phase, which includes hop count determination and training times for the energy predictor (2 days).

C. Simulation Results

1) *Packet overhead*: The average number of bytes of control packets generated by each forwarding strategy, normalized to the total number of bytes of data packets is shown in Fig. 4a. At the lowest traffic, CTP-WUR has a packet overhead which is approximately 3.1 and 3.5 times higher than that of GREENROUTES and WHARP, respectively. This mostly depends on the difference in size of both control and data packets of each forwarding strategies. Specifically, CTP-WUR sends

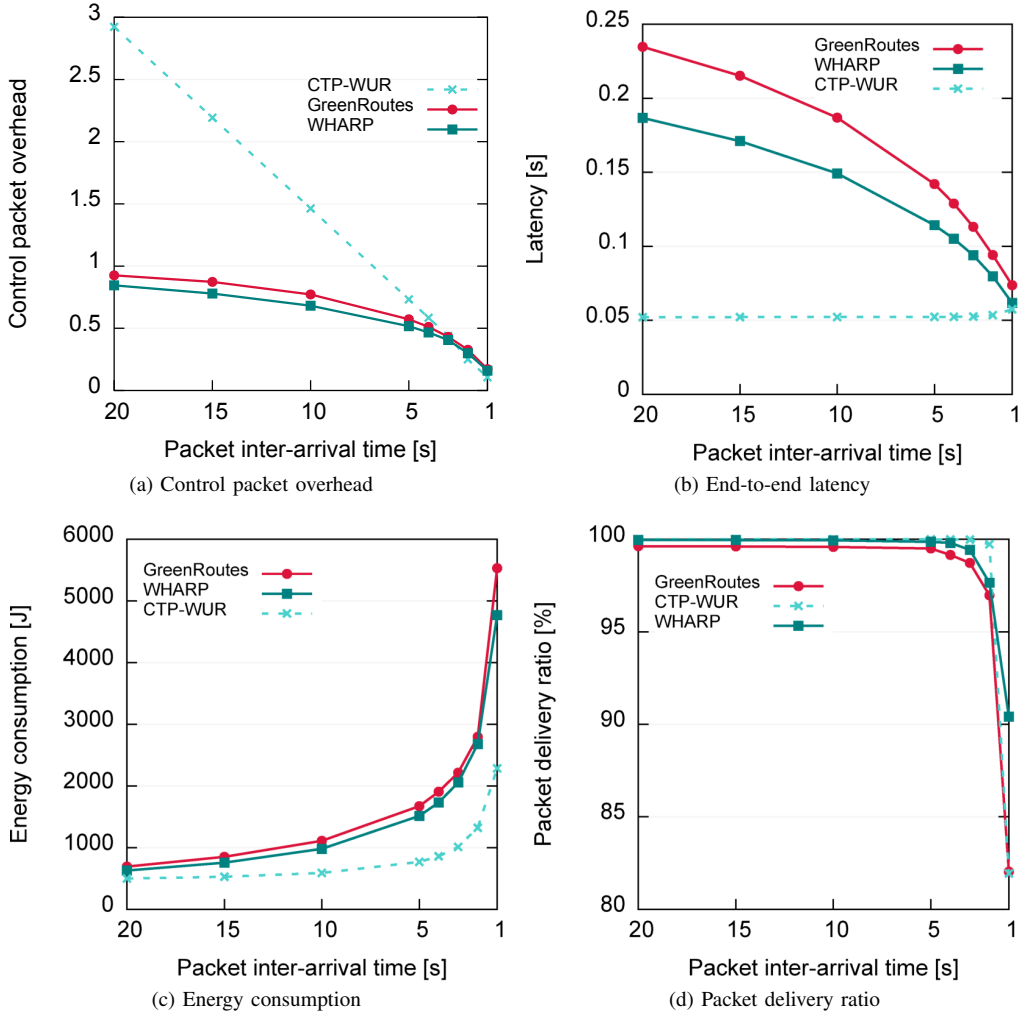

Fig. 4. Performance comparison of CTP-WUR, GREENROUTES and WHARP for increasing traffic.

control packets whose size is 25B, while the total size of control packets in GREENROUTES and WHARP is 14B and 12B, respectively. Both GREENROUTES and WHARP send control packets every time nodes need to forward a data packet (RTS/CTS handshake). We observe that the number of a sender neighbors that wakes up and participates in the handshake on the main radio is slightly inferior for WHARP, because of the optimized policy from the MDP. This justifies the slightly lower packet overhead of WHARP over GREENROUTES. Independently of the forwarding strategy, packet overhead decreases with increasing traffic. In CTP-WUR nodes transmit control packets independently of the traffic load. As a consequence, packet overhead decreases with more data packets being generated. GREENROUTES and WHARP send control packets for route selection (RTS/CTS packets). Therefore, packet overhead would be expected to increase with traffic. However, both protocols take advantage of an “ID caching” mechanism implemented to reduce RTS/CTS-induced overhead (and delays). This mechanism allows a sender node i to store the ID of its last successful relay j for a predefined amount of time τ . All packets that node i

needs to transmit within τ seconds will be transmitted directly to node j , without any new relay selection phase. (In this case, node i will wake up node j directly, i.e., by using its ID as wake-up sequence.) We notice that the higher the traffic, the higher the number of packets to be transmitted within τ seconds, and therefore the lower the number of handshakes for relay selection. As a result, at the highest traffic all three mechanisms have almost the same packet overhead.

2) *End-to-end latency:* The average end-to-end latency for delivering a data packet to the sink is shown in Fig. 4b. Independently of traffic, CTP-WUR consistently delivers packets with lower latency. More specifically, GREENROUTES and WHARP experience latency up to 4.5 and 3.6 times higher than those incurred by CTP-WUR, respectively. This is due to the cross-layer nature of both GREENROUTES and WHARP, requiring nodes to engage in a time consuming RTS/CTS handshake before sending a data packet. Latency remains largely independent of traffic for CTP-WUR, because of the simple tree-based mechanism for determining routes, and the relay of wake up sequences which further reduces route lengths. Latency instead decreases with increasing traffic for

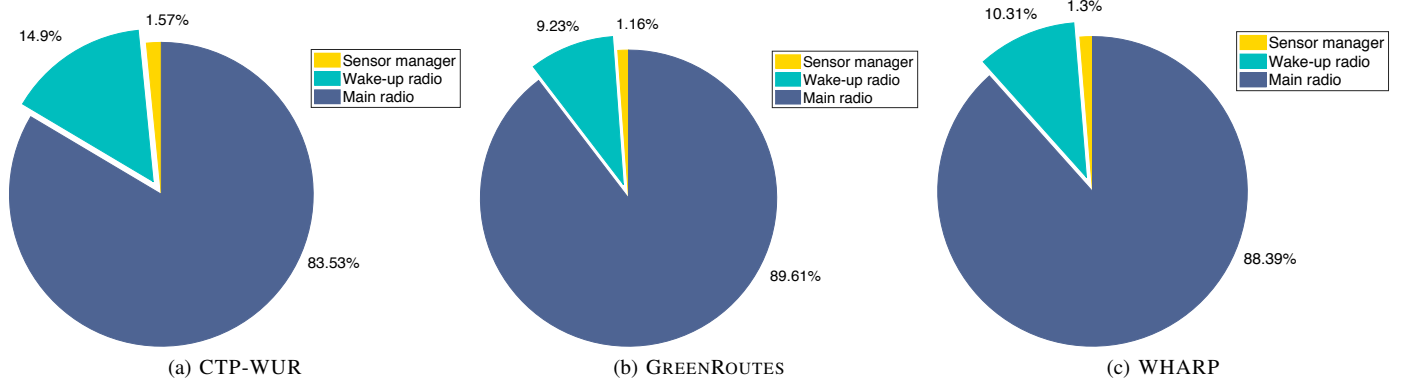

Fig. 5. Energy consumption breakdown in networks with packet inter-arrival time of 10s.

both GREENROUTES and WHARP because of the ID caching mechanism for reducing RTS/CTS-induced delays. We notice that the higher the traffic, the higher the number of packets to be transmitted within τ seconds, and therefore the lower the number of time-consuming handshakes for relay selection (Section III-C1).

3) *Total energy consumption*: Fig. 4c shows the average network energy consumption. Independently of traffic, CTP-WUR always outperforms all other approaches, spending up to 2 and 2.4 times less energy than GREENROUTES and WHARP, respectively. This depends on the relay selection strategy of the latter protocols, which possibly wakes up multiple nodes, whose main radio stays on until the contention for selecting a relay is completed. This does not happen with CTP-WUR, where a node only wakes up one node (its grandparent). As expected, the performance gap among the different protocols increases with traffic. This is due to the higher number of interference among packets, resulting in a higher number of contentions for relay selection and in a higher number of re-transmissions. We notice that GREENROUTES spends slightly more energy than WHARP because its control packets are slightly bigger in size, and also because nodes stay with their main radio on for a longer time.

4) *Packet delivery ratio*: Fig. 4d depicts the average packet delivery ratio of all strategies for increasing traffic. CTP-WUR successfully delivers almost all data packets to the sink for traffic with inter-arrival times higher than 2s. Its performance, however, drops to 82% at the highest considered traffic. This is because of the tree-based topology of CTP-WUR, which provides a node with only one possible relay (its grandparent). As medium/high traffic imposes higher energy consumption, nodes may be non operational for temporary lack of energy for longer times (blacked out nodes). If the grandparent of a sender is blacked out it cannot receive the packet, which will be discarded by the sender after a pre-determined number of transmission attempts. GREENROUTES shows similar performance and similarly suffers from nodes that are blacked out. WHARP instead consistently achieves a packet delivery ratio higher than 90%, irrespective of traffic. This is due to the optimized relay selection policy provided by

the MDP, which takes energy and harvested energy explicitly into account, makes nodes avoid waking up if they are not a good fit, and explicitly penalizes choosing relays to routes with blacked out nodes.

Fig. 5 and Fig. 6 depict results that allow us to delve deeper into the differences of the three strategies concerning their use of energy. Particularly, Fig. 5 shows the energy consumed by the sensor manager, the main radio, and the wake-up radio when running CTP-WUR (Fig. 5a), GREENROUTES (Fig. 5b), and WHARP (Fig. 5c) in networks with moderate traffic (the packet inter-arrival time is 10s). The energy consumed is expressed as the percentage of the total energy consumed by each forwarding strategy. The main radio drains most of the available energy, independently of the forwarding strategy. We observe that the energy consumed by the wake-up radio for transmitting a wake-up sequence is around three times higher than the energy consumed by the main radio for transmitting a data packet. Despite data packets are longer, the time needed to transmit the 8 bits of a wake-up sequence at 1kbps is higher, hence the higher amount of energy drained. The dominant component of the overall energy consumption is however due to the reception of packets on the main radio. For instance, in CTP-WUR, due to data packets and control packets reception, the main radio stays in receiving mode 16 times longer than in transmission. This number grows to 64 and 56 times more in GREENROUTES and WHARP, respectively, as their relay selection strategy wakes up multiple nodes, and makes them stay in receiving mode for significant amounts of time. The energy consumed by the wake-up radio for receiving a wake-up sequence is negligible, as our receiver consumes in the μW , and stays receiving for short periods of time. This motivates why the energy consumed by the main radio is dominant, with consumption from 5.6 to 9.7 times higher than those incurred by the wake-up radio.

Fig. 6 shows the snapshot of a selected, exemplary topology, with the sink placed at the upper right corner (depicted as a black star). This scenario refers to a network with medium/high traffic (the packet inter-arrival time is 1s). Sensor nodes are depicted as circles or triangles, depending on their energy source, sun or wind, respectively. The color of a node

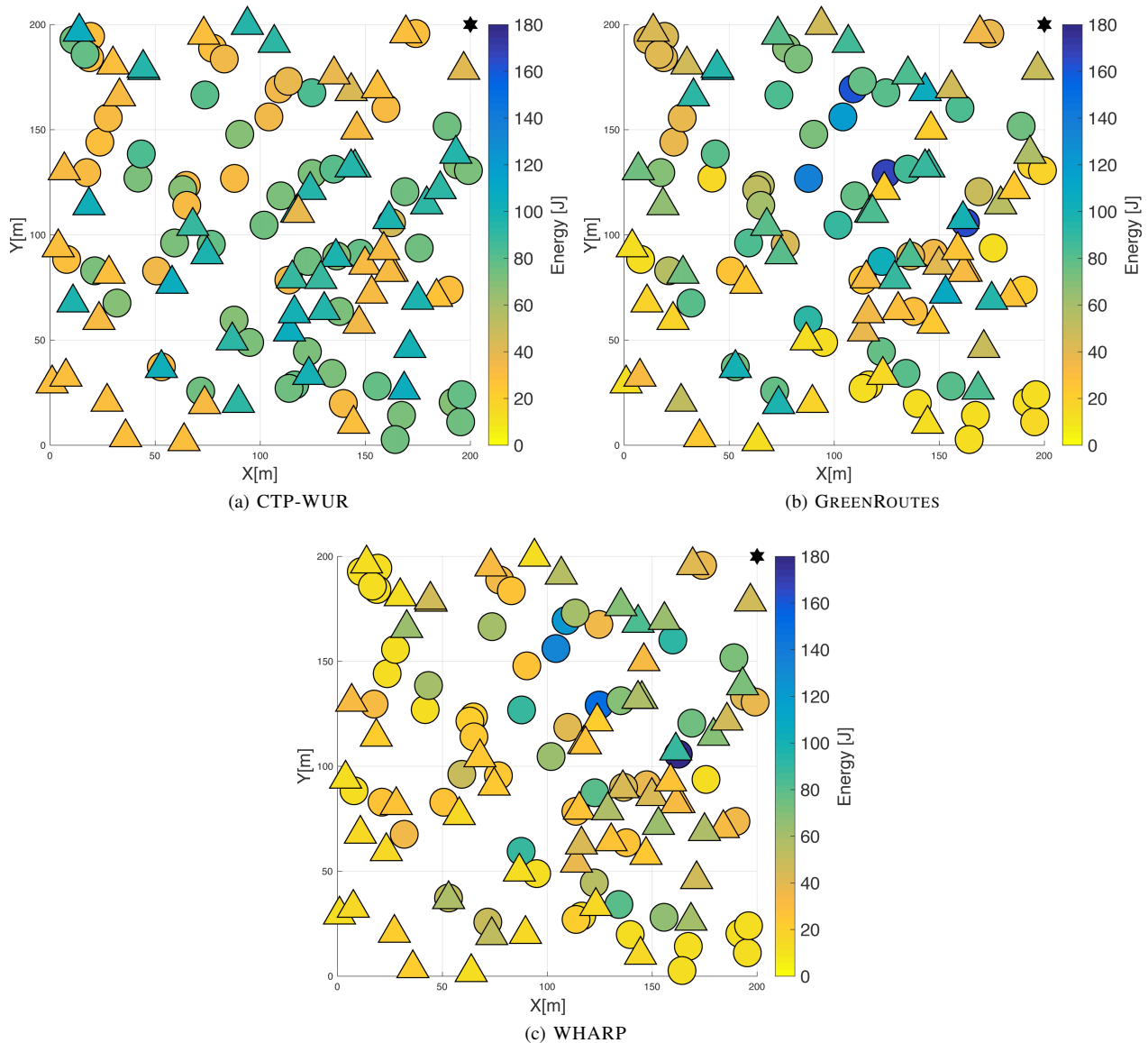

Fig. 6. Per node energy consumption in networks with medium/high traffic and heterogeneous energy harvesting sources.

indicates the energy it consumed throughout the simulation time: The darker the color, the higher the energy consumed. No node running CTP-WUR is colored in the darker shades (Fig. 6a), which is indicative of the fact that, overall, it is the most energy-efficient solution (see also Fig. 4c and Fig. 5a). Some of the nodes running GREENROUTES and WHARP instead sport darker colors (Fig. 6b and Fig. 6c, respectively). This indicates that, especially at the highest traffic considered, they stay with their main radio on for longer periods of time. We observe that among the three forwarding strategies, the only one that is capable of effectively avoid draining energy from the most energy challenged nodes (typically those powered by wind energy) is WHARP. This is because the WHARP relay selection strategy is driven by a Markov Decision Process that explicitly penalizes selecting nodes that could black out in the near future. As a result, aside from the

nodes closer to the sink (“funneling effect”), most of the nodes running WHARP show low to moderate energy consumption.

IV. RELATED WORKS

This section aims at providing a brief recount of data forwarding strategies for WSNs, with an emphasis on networks with energy harvesting and on networks with wake-up radios. A plethora of works has been proposed that present design and development of forwarding strategies in WSNs. Energy efficient approaches have been discussed and evaluated in depth through surveys, reviews, and comparative studies [20], [21], [22]. For what concerns research on WSNs where nodes are capable of energy harvesting, works are typically confined to surveys with limited comparative analysis of existing solutions. Babayo et al. present a review paper where various energy management schemes are classified based on the

energy-requirements of applications [23]. While the authors give several useful insights on how various existing works fall into different categories, this work is not a comparative study and provides little insights on protocol design. Similarly, the survey by Khan, Qureshi, and Iqbal provides a baseline discussion on developing energy efficient management schemes in WSNs [24]. They also investigate existing solutions from an energy perspective, where energy management can be handled on the basis of energy provisioning or energy consumption. A useful and quite comprehensive introduction to energy harvesting-based WSNs is provided by Basagni et al. [4] and by Mishra et al. [5]. These works mainly aim at exploring the opportunities and challenges of using these networks rather than presenting a comparative analysis of existing solutions. A performance evaluation of routing protocols in device-to-device energy harvesting-based networks is presented in [25]. Two well-known routing protocols, namely Optimized Link State Routing (OLSR) and Ad hoc on Demand Distance Vector (AODV), are evaluated and their performance is compared. These two protocols, however, are not specifically designed for green wireless networks, they are not considered to be energy-aware, and their performance evaluation is limited only to two energy-related metrics and to packet delivery ratio. Eu et al. investigate the performance of different MAC schemes adapted to WSNs with energy harvesting capabilities under several metrics [26]. Through simulations, the authors discuss the behavior of the investigated approaches and how different parameters affect their performance. However, this work does not discuss any data forwarding strategies, which is the main concern of our work. A comparison of routing protocols for WSNs powered by ambient energy harvesting is provided by Hasenfratz et al. in [27]. Through a GreenCastalia-based simulation comparison, the authors analyze the performance of three routing approaches, namely, E-WME, R-MF, and R-MPRT. Their comparison is based on two performance metrics: Packet loss and energy consumption. Protocols are evaluated under several realistic scenarios, including usage of a low-power MAC protocol and models for lossy wireless channels. The protocols considered in this work have similar design, and do not consider cross-layer approaches.

In the realm of WSNs with wake-up radio capabilities, besides the protocols considered in the present work, the works by Petrioli et al. [8], Spenza et al. [6], and Kumberg et al. [28] are worth citing. The first work is about the effectiveness of using wake-up radios for abating the latencies and energy consumption typical of solutions based on duty cycling [8]. This work also serves the purpose of introducing a new architecture for a wake-up radio. Two simple protocols, unicast and broadcast-based, are described and compared to show that usage of wake-up radios allows remarkable performance improvements. The second work presents ALBA-WUR, which is the version for wake-up radio of ALBA-R, an energy efficient data forwarding protocol for WSNs [29]. Besides showing once more the remarkable performance improvements achievable via wake-up radios, this work shows the flexibility of wake-up radio semantic addressing for re-designing com-

plex data forwarding strategies. Finally, the work by Kumberg et al. presents a new data forwarding protocol for WSNs with wake-up radios, named T-ROME, and compares it with CTP-WUR [28]. The main aim of the work is that of presenting a new protocol capable of taking advantage of wake-up radios. None of these works considers nodes with energy harvesting capabilities, or it is explicitly concerned with extensive performance comparisons under multiple metrics.

All the works cited show a clear trend towards networks whose nodes and their protocol stack are fully aware of both energy harvesting and wake-up radio capabilities: Green wireless networks. Studies on protocol design, on performance comparisons, and on solution testing are still largely uncharted territory. Our work aims at starting the exploration of data forwarding solutions for green wireless networks, and to provide insights about which design choices are best for achieving the performance needed by critical applications of WSNs.

V. CONCLUSIONS

This paper presents a comparative performance evaluation of three data forwarding strategies for green wireless networks, where protocol design takes explicitly into account usage of a wake-up radio, and where nodes are capable of energy harvesting. All three approaches, namely, CTP-WUR, GREENROUTES and WHARP, achieve exemplary performance under a variety of performance metrics. The results of our GreenCastalia-based simulations show that approaches like WHARP and GREENROUTES that rely on contention-based mechanisms for relay selection incur high latency and energy consumption as the contention itself is time-consuming and involves multiple potential next-hop relays. Approaches like CTP-WUR obtain instead faster and lighter performance, because of the more traditional, more proactive way of determining routes. However, in energy harvesting-based networks where nodes can temporarily black out these approaches incur packet loss due to the lack of timely topology updates. It takes the sophistication of machine learning to allow design à la WHARP to succeed in selecting next-hop relays along routes without nodes that black out. We finally observe that the use of techniques to directly forward data packets to a known and already used next-hop relay (“ID caching”), as in GREENROUTES and WHARP, can decrease end-to-end latency to values similar to that of strategies which do not require the transmission of control packets for channel reservation, such as CTP-WUR.

ACKNOWLEDGMENTS

This project is partially supported by the MIUR Smart City Smartour project and by the MIUR-funded project for the Italian Technology Cluster for Smart Communities Techs. Stefano Basagni was supported in part by the U.S. Office of Naval Research under grant N00014-17-1-2046.

REFERENCES

- [1] F. K. Shaikh and S. Zeadally, “Energy harvesting in wireless sensor networks: A comprehensive review,” *Renewable and Sustainable Energy Reviews*, vol. 55, pp. 1041–1054, March 2016.

- [2] A. Z. Kausar, A. W. Reza, M. U. Saleh, and H. Ramiah, "Energizing wireless sensor networks by energy harvesting systems: Scopes, challenges and approaches," *Renewable and Sustainable Energy Reviews*, vol. 38, pp. 973–989, October 2014.
- [3] T. Rault, A. Bouabdallah, and Y. Challal, "Energy efficiency in wireless sensor networks: A top-down survey," *Computer Networks*, vol. 67, pp. 104–122, July 2014.
- [4] S. Basagni, M. Y. Naderi, C. Petrioli, and D. Spenza, "Wireless sensor networks with energy harvesting," in *Mobile Ad Hoc Networking: The Cutting Edge Directions*. Hoboken, NJ: John Wiley and Sons, Inc., 2013, ch. 20, pp. 701–736.
- [5] D. Mishra, S. De, S. Jana, S. Basagni, K. R. Chowdhury, and W. Heinzelman, "Smart RF energy harvesting communications: Challenges and opportunities," *IEEE Communications Magazine*, vol. 53, no. 4, pp. 70–78, April 2015.
- [6] D. Spenza, M. Magno, S. Basagni, L. Benini, M. Paoli, and C. Petrioli, "Beyond duty cycling: Wake-up radio with selective awakenings for long-lived wireless sensing systems," in *Proceedings of IEEE Infocom 2015*, Hong Kong, China, April 26–30 2015, pp. 522–530.
- [7] C. Li, J. Warner, P. L. Yung, D. Zhou, W. Heinzelman, I. Demirkol, U. Muncuk, K. R. Chowdhury, and S. Basagni, "Reach²-mote: A range extending passive wake-up wireless sensor node," *ACM Transactions on Sensor Networks*, vol. 11, no. 4, pp. 64:1–64:33, December 2015.
- [8] C. Petrioli, D. Spenza, P. Tommasino, and A. Trifiletti, "A novel wake-up receiver with addressing capability for wireless sensor nodes," in *Proceedings of IEEE DCOSS 2014*, Marina Del Rey, CA, May 26–28 2014, pp. 18–25.
- [9] S. Basagni, C. Petrioli, and D. Spenza, "CTP-WUR: The collection tree protocol in wake-up radio WSNs for critical applications," in *Proceedings of IEEE ICNC 2016*, Kauai, HI, February 15–18 2016, pp. 1–6.
- [10] O. Gnawali, R. Fonseca, K. Jamieson, D. Moss, and P. Levis, "Collection tree protocol," in *Proceedings of ACM SenSys 2009*, Berkeley, CA, November 4–6 2009, pp. 1–14.
- [11] S. Basagni, V. Di Valerio, G. Koutsandria, and C. Petrioli, "Wake-up radio-enabled routing for green wireless sensor networks," in *Proceedings of IEEE VTC 2017 Fall*, Toronto, Ontario, CA, September 24–27 2017, pp. 1–6.
- [12] S. Basagni, V. Di Valerio, G. Koutsandria, C. Petrioli, and D. Spenza, "WHARP: A wake-up radio and harvesting-based forwarding strategy for green wireless networks," in *Proceedings of IEEE MASS 2017*, Orlando, FL, October 24–27 2017, pp. 257–265.
- [13] D. Benedetti, C. Petrioli, and D. Spenza, "GreenCastalia: An energy-harvesting-enabled framework for the Castalia simulator," in *Proceedings of ACM ENSSys 2013*, Rome, Italy, November 13 2013, pp. 1–6.
- [14] A. Boulis, "Castalia: Revealing pitfalls in designing distributed algorithms in WSN," in *Proceedings of ACM SenSys 2007*, Sydney, Australia, November 6–9 2007, pp. 407–408.
- [15] M. Paoli, D. Spenza, C. Petrioli, M. Magno, and L. Benini, "MagoNode++: A wake-up radio-enabled wireless sensor mote for energy-neutral applications," in *Proceedings of ACM/IEEE IPSN 2016*, Vienna, Austria, April 11–14 2016, pp. 1–2.
- [16] S. Basagni, F. Ceccarelli, F. Gattuso, and C. Petrioli, "Demo abstract: Abating LPL-induced latency with wake-up radio technology," in *Proceedings of ACM IoT DI 2017*, Pittsburgh, PA, April 18–21 2017, pp. 1–2.
- [17] T. Instruments, "CC1101 datasheet," rev. SWRS061I, 2013.
- [18] NREL: Measurement and instrumentation data center. [Online]. Available: <http://www.nrel.gov/midc>
- [19] F. I. Simjee and P. H. Chou, "Efficient charging of supercapacitors for extended lifetime of wireless sensor nodes," *IEEE Transactions on Power Electronics*, vol. 23, no. 3, pp. 1526–1536, May 2 2008.
- [20] S. Ehsan and B. Hamdaoui, "A survey on energy-efficient routing techniques with QoS assurances for wireless multimedia sensor networks," *IEEE Communications Surveys & Tutorials*, vol. 14, no. 2, pp. 265–278, Second Quarter 2012.
- [21] C. Wei, J. Yang, Y. Gao, and Z. Zhang, "Cluster-based routing protocols in wireless sensor networks: A survey," in *Proceedings of ICCSNT 2011*, Harbin, China, December 24–26 2011, pp. 1659–1663.
- [22] N. A. Pantazis, S. A. Nikolidakis, and D. D. Vergados, "Energy-efficient routing protocols in wireless sensor networks: A survey," *IEEE Communications Surveys & Tutorials*, vol. 15, no. 2, pp. 551–591, Second Quarter 2013.
- [23] A. A. Babayo, M. H. Anisi, and I. Ali, "A review on energy management schemes in energy harvesting wireless sensor networks," *Renewable and Sustainable Energy Reviews*, vol. 76, pp. 1176–1184, September 2017.
- [24] J. A. Khan, H. K. Qureshi, and A. Iqbal, "Energy management in wireless sensor networks," *Computers and Electrical Engineering*, vol. 41, pp. 159–176, January 2015.
- [25] S. Riaz, H. K. Qureshi, and M. Saleem, "Performance evaluation of routing protocols in energy harvesting D2D network," in *Proceedings of ICE Cube 2016*, Quetta, Pakistan, April 11–12 2016, pp. 251–255.
- [26] Z. A. Eu, H.-P. Tan, and W. K. Seah, "Design and performance analysis of MAC schemes for wireless sensor networks powered by ambient energy harvesting," *Ad Hoc Networks*, vol. 9, no. 3, pp. 300–323, 2011.
- [27] D. Hasenfratz, A. Meier, C. Moser, J. J. Chen, and L. Thiele, "Analysis, comparison, and optimization of routing protocols for energy harvesting wireless sensor networks," in *Proceedings of IEEE SUTC 2010*, Newport Beach, CA, June 7–9 2010, pp. 19–26.
- [28] T. Kumberg, M. Schink, L. M. Reindl, and C. Schindelbauer, "T-ROME: A simple and energy efficient tree routing protocol for low-power wake-up receivers," *Ad Hoc Networks*, vol. 59, pp. 97–115, 2017.
- [29] C. Petrioli, M. Nati, P. Casari, M. Zorzi, and S. Basagni, "ALBA-R: Load-balancing geographic routing around connectivity holes in wireless sensor networks," *IEEE Transactions on Parallel and Distributed Systems*, vol. 24, no. 3, pp. 529–539, March 2014.