

Electronics
EECE2412 — Spring 2018
Exam #2

Prof. Charles A. DiMarzio
Department of Electrical and Computer Engineering
Northeastern University

File:12262/exams/exam2

29 March 2018

Name: _____

General Rules:

- You may make use of two sheets of notes, 8.5-by-11 inches, using both sides of the page.
- You may use a calculator.
- Present your work as clearly as possible. I give partial credit if I can figure out that you know what you are doing. I do not give credit for putting down everything you know and hoping I will find something correct in it.
- Each question has a vertical black bar providing space for your work and a line for numerical answers or box for plots or drawings. Please write your answer to each question clearly. If it happens to be correct, I give you points quickly and move on to the next problem. Please show your work in the space provided, or on extra pages, clearly labeled with the problem number. If the answer is wrong, this will make it easy for me to find ways to give you partial credit.
- Avoid any appearance of academic dishonesty. Do not talk to other students during the exam. Keep phones, computers, and other electronic devices other than calculators secured and out of reach.

1 Short-Answer Questions

1. It is not possible to have zero DC voltage on both the input and output of a single-stage common-emitter amplifier.

True
 False

2. The Early Voltage is a measure of

the base-collector voltage.
 the slope of i_C plotted against v_{CE}
 the slope of i_C plotted against v_{BE}

3. The collector-emitter voltage of a BJT in saturation is

0.2 V
 0.5 V
 0.7 V

4. Delay in BJT logic gates results in delay in the output but the outputs are always correct.

True
 False

5. A common-emitter amplifier provides

Unit current gain.
 Unit voltage gain.
 High gain.

6. The emitter resistor in a common-emitter amplifier

Helps set the DC bias.
 Reduces the amplifier gain.
 Both of the above.

7. BJT Logic circuits have the following properties. Check all correct answers.

- They are fast enough to be used in modern computers.
- They consume large amounts of power.
- They cannot be used in long chains.

8. The arrow on a BJT symbol is on the

- Emitter.
- Base.
- Collector.

9. A PNP transistor in a certain circuit is in active mode. The collector is connected to ground through a resistor. The emitter is connected to

- a positive voltage.
- ground.
- a negative voltage.

10. Transconductance depends strongly on the Beta of the transistor.

- True
- False

2 BJT DC Bias

Consider the circuit in the figure. The transistor has $\beta = 100$. $R_1 = 270 \text{ k}\Omega$, $R_2 = 160 \text{ k}\Omega$, $R_{E1} = 0$, $R_{E2} = 2 \text{ k}\Omega$, $R_C = 4.5 \text{ k}\Omega$. All capacitors are “large enough” and $V_{CC} = V_{EE} = 9 \text{ V}$.

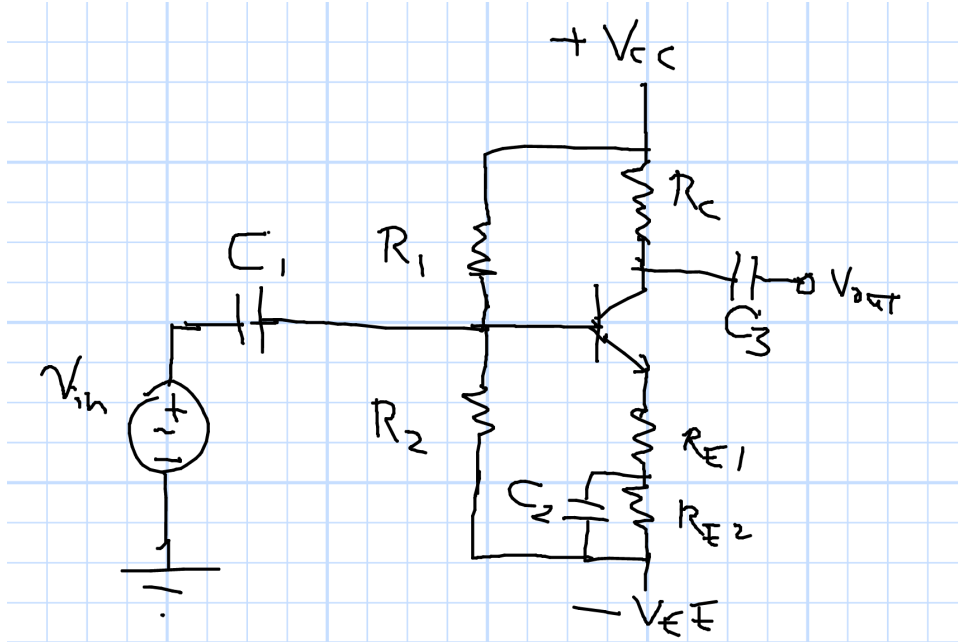

2.1 DC Circuit

Find a Thevenin equivalent for the base circuit and then draw the DC circuit. Label all the components with their values.



2.2 Bias

What is the DC base current?

$$I_B = \text{_____ mA.}$$

What is the DC collector current?

$$I_C = \text{_____ mA.}$$

What is the DC voltage at the collector?

$$V_C = \text{_____ V.}$$

What is the DC voltage at the emitter?

$$V_E = \text{_____ V.}$$



3.2 Amplifier Parameters

What is the voltage gain?

$$A_V = \underline{\hspace{10cm}} .$$

What is the input impedance?

$$Z_{in} = \underline{\hspace{10cm}} \text{ Ohms.}$$

What is the output impedance?

$$Z_{out} = \underline{\hspace{10cm}} \text{ Ohms.}$$



4 BJT Logic

Consider the logic inverter circuit shown in the figure. The transistor has $\beta = 200$. $R_b = 10 \text{ k}\Omega$ and $R_c = 1 \text{ k}\Omega$.

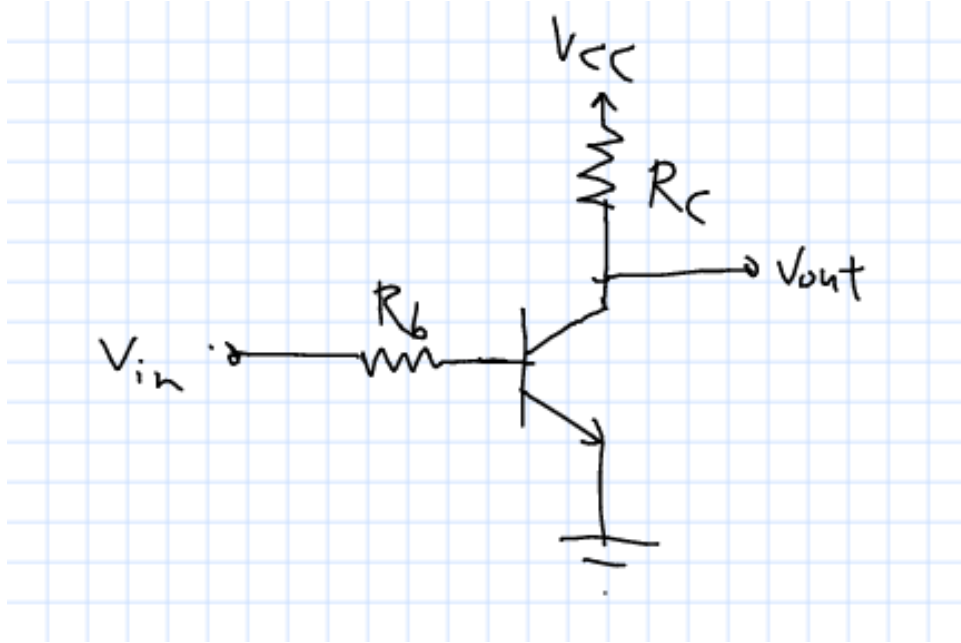

4.1 Transfer Characteristic

Treat the circuit as an amplifier and calculate the gain. Then carefully draw a plot of the transfer characteristic, v_{OUT} as a function of v_{in} . Use a range of zero to V_{CC} on both axes.



4.4 Power

How much power is consumed by the circuit (both transistor and resistor) when the output is “high?”

How much power is consumed by the circuit when the output is “low?”
