

EECE 2413

Electronics Laboratory

Lab #4: BJT Amplifiers

Goals

In this lab you will experiment with BJT amplifiers. The *common emitter* (CE) amplifier is the most basic. You will examine the voltage gain, clipping, sensitivity to V_+ , and frequency response of this amplifier. For this configuration the gain and operating point depend on g_m and β .

Since circuits must be designed to allow for wide variations in β , negative feedback will be used to stabilize the gain and Q-point. This is accomplished by adding an emitter resistor. In this configuration, the voltage gain is very stable, but the gain is also much lower.

As always, take your time during these experiments. Think about *what* you are being asked to do and *why* the experiments are important.

Once you are comfortable with these basic BJT amplifiers, you will design and test your own high-gain amplifier by cascading two basic amplifiers.

Prelab

Prelabs will be collected for grading at the beginning of the lab. Keep a copy for your own use during the lab!

1. Show that the operating point (Q) of the amplifier in Figure 2 is relatively stable against variations in β by finding I_C and V_C when $\beta=80$ and $\beta=300$.
2. Read the lab experiment and see the instructor with any questions you may have.
3. Read Part 2 and sketch a circuit you think will work. (You may change your design as you work through the lab, however.)

Part 1: BJT amplifier characteristics

Concept: The signal generator

You will be using the signal generator on the bench as an input to all of your amplifiers.

The signal generator provides a steady and controllable signal which is useful for testing circuits, so a generator is usually chosen as the input source during initial circuit design. This signal generator would be replaced by a microphone, a radio antenna, or other practical, low-level signal in a real-life situation.

Since you will want to look at the input signal on the oscilloscope *and* provide the same signal to the amplifier, place a BNC Tee on the generator output marked “MAIN OUT, LO”. Use a BNC cable to connect the generator to *channel 1* of the oscilloscope. Familiarize yourself with the generator and the oscilloscope by adjusting each until you can see a signal with the following properties:

signal: SINE WAVE
amplitude: 10 mV zero-to-peak (as *small* as possible)
frequency: 1 kHz
offset: 0 volts

Concept: The common emitter amplifier gain

Figure 1 shows a typical common emitter amplifier. Build this circuit on your protoboard. For the sake of mechanical stability, use the banana plug terminals on the board for V+, the signal generator input, and the output to *channel 2* of the oscilloscope. Since all of your signals use a common ground, you may use the terminal marked with the ground symbol for all three of these inputs/outputs.

Try to keep the leads on your circuit as short as possible and be careful that all connections are secure. You will be amplifying very low-level, high frequency input signals in this experiment, **so attention to the circuit layout is important.** Loose connections and large loops of hook-up wire are susceptible to noise. If your amplifier circuits begin to oscillate, check that input and output wires are not near each other. Crosstalk of the output signal with the input signal creates a feedback loop which is similar to holding a microphone too close to a loud speaker.

When the circuit is complete...

- a) Verify that the BJT is biased in the forward active region by measuring and recording the appropriate voltages. **Include this information in your lab report and explain why the BJT is in the forward active region.**
- b) Determine and record the collector current when $V_{in} = 0$. This gives the operating point I_C . **Determine the transconductance of the BJT from $g_m = I_C/V_T$ where $V_T = 26$ mV.** Notice that C_B decouples the base terminal from the generator under DC conditions. If C_B were not used, the input would be shorted to ground when $V_{in} = 0$ and the BJT would be biased in the cut-off region.
- c) Experimentally determine the DC value of β for this transistor.

d) Calculate r_π from β/g_m . Assume that the DC value of β and the small signal value for β are equal.

e) Calculate the voltage gain of this amplifier. Note that R_S for our signal generator is $50\ \Omega$, but you are measuring V_{in} at a node *after* R_S . Therefore, take R_S to be equal to zero. (Hint: use g_m and R_C when calculating this voltage gain.)

Using both input channels of the oscilloscope, display the input and output voltages simultaneously. If you are using the analog oscilloscope, be sure to use the “chop” setting, rather than “alternate” so the phase relationship between the two signals is maintained by the oscilloscope. For the digital oscilloscope, it is automatically set to “chop”. Notice that the output is 180° out of phase with the input. The CE amplifier is an *inverting* amplifier, therefore $A_V < 0$.

f) Record the amplitudes of the input and output voltages and find the voltage gain, A_V . **How do the measured and calculated gains compare?** Assume that $r_O \gg R_C$.

The discrepancy in the calculated gain is due to several factors. The simplest factor we have ignored is the *base spreading resistance*, r_b . This parasitic resistance appears between the base wire of the transistor and the actual base-emitter junction (which is modeled by r_π). Since r_π and r_b form a simple voltage divider, the r_b reduces the voltage gain by $r_\pi / (r_b + r_\pi)$ when the base spreading resistance is included in the gain calculation.

Recalculate the voltage gain including $r_b = 200\ \Omega$.

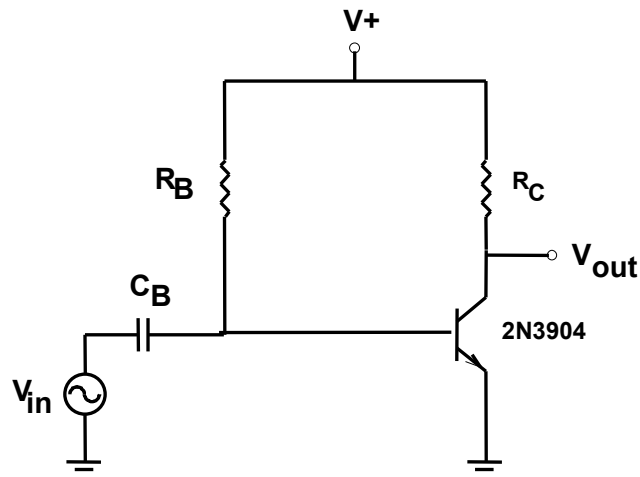

Figure 1. A Common Emitter Amplifier
 $R_B = 309\ \text{k}\Omega$, $R_C = 1\ \text{k}\Omega$, $C_B = 1.5\ \mu\text{F}$
 $V+ = 10\ \text{volts (nom.)}$, $V_{in} = 10\ \text{mV zero-to-peak}$

Concept: clipping and the limits of small signal analysis

Slowly increase the amplitude of the input voltage while observing the output voltage. Notice that the output begins to distort and eventually the top and/or bottom of the waveform clips-off. If the input is large enough, the output looks like a square wave.

- g) Record the maximum and minimum obtainable output voltages when the amplifier is clipping (be sure the oscilloscope is set to DC coupling, not AC coupling!) **Explain the reason for the maximum and minimum voltages, that is, why doesn't the amplifier output voltage go higher and why doesn't the amplifier output go lower?**

Concept: Sensitivity of the voltage gain to V_+

The common emitter amplifier is sensitive to changes in the supply voltage V_+ . To observe this, first reset the input signal voltage to 10 mV.

- h) Now change V_+ to 8 volts. Measure and record the voltage gain.
- i) Set V_+ to 12 volts. Measure and record the voltage gain.
- j) **Explain why the voltage gain depends on V_+ . Hint: $A_v \sim -g_m R_C$. Give a real-life example where this sensitivity might cause a problem.**

Concept: The variation of voltage gain with frequency (the "frequency response")

Reset V_+ to 10V. Increase the frequency of the input signal while observing the output voltage on the oscilloscope. Around 1 MHz you will see the output amplitude begin to decrease. The upper cut-off frequency is usually defined as the frequency at which the output decreases by 3 dB (decibels). Since $-3 \text{ dB} = 20 \log_{10}(1/\sqrt{2})$, the upper cut-off frequency occurs when the output decreases by a factor of $1/\sqrt{2}$ (or 0.707) from its mid-frequency amplitude.

- k) Find and record the upper cut-off frequency of this amplifier.

The amplifier gain decreases at high frequency due to parasitic (unwanted) capacitance in the two *pn*-junctions which make up the *npn* transistor. These capacitances lie between the base-and-emitter and the base-and-collector. Recall that capacitors behave like short-circuits at high frequency. Knowing this fact, you can see that the parasitic capacitors effectively short-out the base to the collector and emitter terminals. This disables the transistor at high frequency.

- l) Using the same criteria as (k), find the *lower* cut-off frequency.

The lower cut-off frequency is determined by the coupling capacitor, C_B . At very low frequencies, capacitors act like open circuits. Therefore as f decreases, C_B looks more and more like an open circuit. This has the effect of disconnecting the signal source from the base of the BJT.

The audio band is 20 Hz-20 kHz, the AM radio band is 0.54-1.6 MHz, and the FM band is 88-108 MHz. **For which application(s) is this amplifier suitable? How could you make the amplifier operate at a lower frequency? Try out your solution and describe the method in your report.**

Concept: A stable amplifier -- the common emitter with R_e

The gain and bias stability problems we have encountered with the CE amplifier (*see Lab 2*) can be solved by adding a resistor at the emitter of the BJT as shown in Figure 2. Build this circuit and verify that the BJT is biased in the active region.

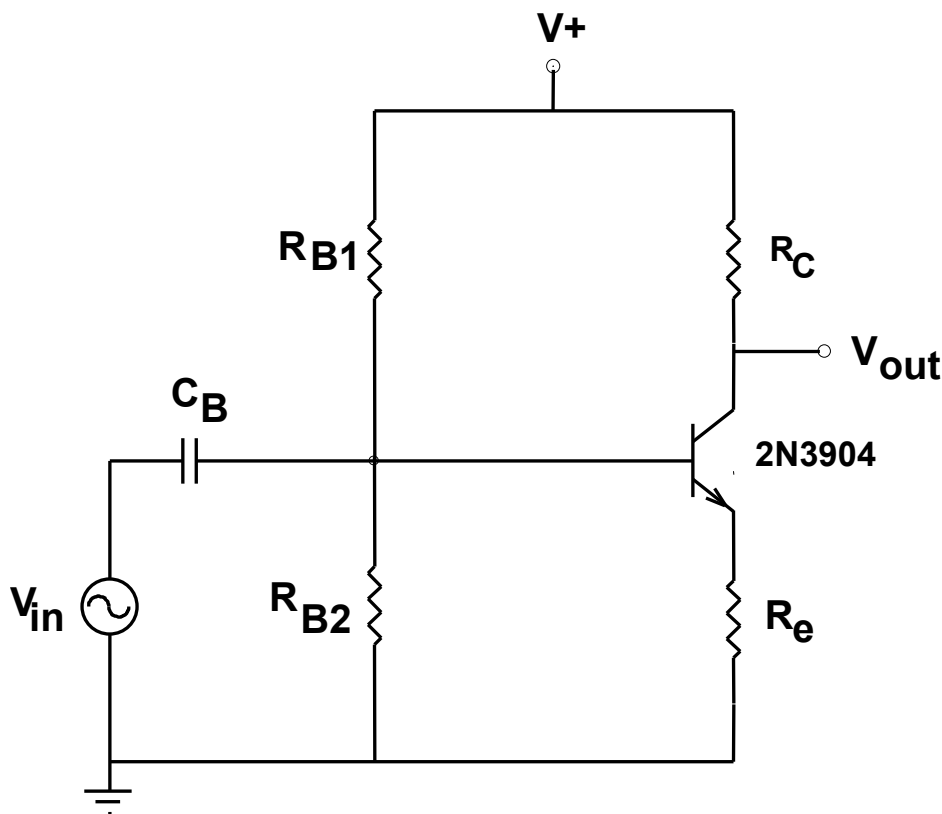

Figure 2. A stabilized BJT amplifier -- Common Emitter with R_e
 $R_{B1} = 47 \text{ k}\Omega$, $R_{B2} = 10 \text{ k}\Omega$, $R_C = 1 \text{ k}\Omega$, $R_e = 220 \text{ }\Omega$, $C_B = 1.5 \text{ }\mu\text{F}$,
 $V_{in} = 100 \text{ mV}$ zero-to-peak with $f = 1 \text{ kHz}$, $V+ = 10 \text{ volts (nom.)}$

m) Measure and record the voltage gain for $V_+ = 8, 10,$ and 12 volts. **Is this amplifier configuration sensitive to V_+ ?**

n) Make β of the BJT decrease by spraying the transistor with coolant. **Did the gain decrease?**

The voltage gain of the CE with R_e amplifier is given by $A_V \approx -R_C/R_e$. Notice that this gain does not depend on β ! This is very important to remember when designing an amplifier since we know from Lab3 that β varies from BJT-to-BJT and with temperature.

o) **Calculate A_V and compare the result with the measurement from part (m).**

The disadvantage of the CE with R_e amplifier is probably obvious to you by now. The gain went from >100 to <10 . We can increase the gain by adding an emitter capacitor, C_E , as shown in Figure 3. Since the capacitor acts like an open circuit under DC conditions, the **bias point** is still stabilized against changes in β . At the signal frequencies that we want to amplify however, C_E acts like a short circuit. This effectively shorts-out R_e and increases $|A_V|$ to the level of a common emitter stage. This amplifier is *not* perfect since A_V is once again sensitive to β and V_+ . In Electronics II you will investigate *feedback* as a way of controlling amplifier performance.

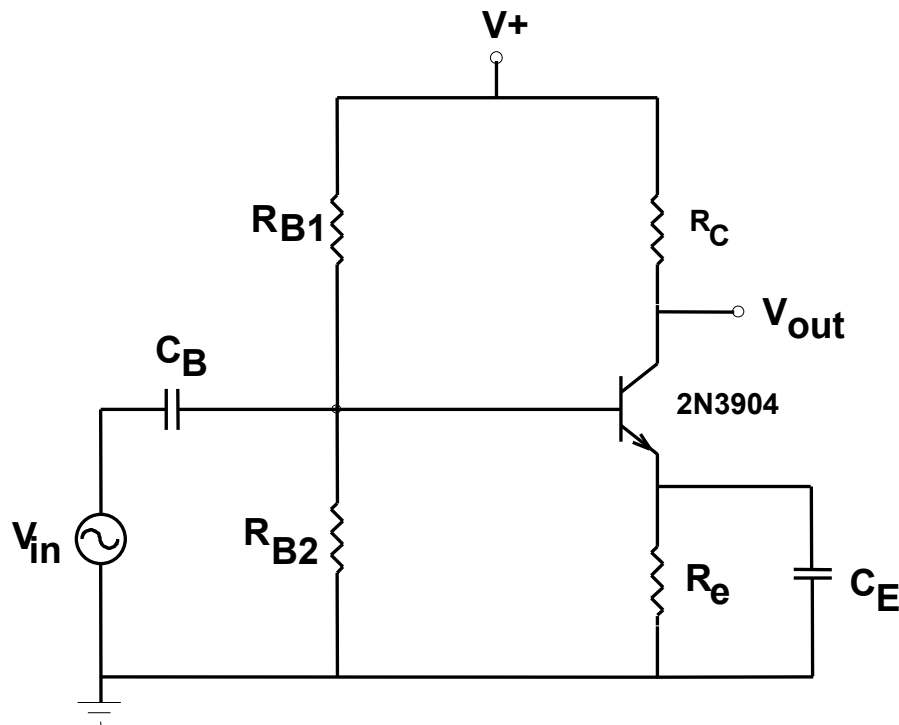

Figure 3. A bias-stabilized common emitter amplifier

Note: $C_E = 100 \mu\text{F}$, the “+” terminal should be connected to the emitter of the BJT

Shop Note: Electrolytic capacitors, like the one shown in Figure 3, are polarized...that is, they have + and - terminals. If you connect the capacitor with reversed polarity, it will “leak” a small but devastating DC current through its terminals.

p) Add a 100 μF electrolytic capacitor in parallel with R_e . Measure and record the voltage gain when $f=1$ kHz. **How does this compare with the CE amplifier?**

One final note: You could stabilize the bias point *and* gain by splitting R_e into two smaller resistances, $R_{e1} + R_{e2} = R_e$. Applying the bypass capacitor (C_E) across R_{e2} *only* gives us a nice compromise between good bias stability and high voltage gain.

Part 1 of this lab is now complete. As usual, the lab report is due in one week.

Part 2: Designing a stable amplifier with high voltage gain

Design and build an amplifier with $|A_v| = 20 \pm 1$. The amplifier should be insensitive to changes in V_+ in the range of 10 ± 2 volts. It should also be insensitive to changes in β due to temperature.

When your design is working, draw a schematic of the circuit in your lab notebook, record the voltage gain for supply voltages of 8, 10, and 12 volts. Also, record the voltage gain when the BJT is cooled using refrigerant. Demonstrate that the amplifier is stable to the instructor, and get the instructor's *design approval* on your schematic.

JH10.96
Rev. 8.05
Rev. 7.08
Rev. 6.10

Equipment List -- Lab #4

Note: "*" indicates this component was used in Lab 1 & 2.

Agilent E3647A dual output power supply *
Fluke 8010A digital multimeter *
Fluke 45 Dual Display Multimeter *
Proto-Board model PB-103 *
Agilent MSO6012A mixed-signal oscilloscope *
Agilent 33220A function generator *

#20 hook up wire *
wire strippers *
Banana plug-terminated test leads *
BNC-to-BNC cable
BNC-to-Banana plug cable (2)
BNC Tee
Aerosol coolant *

Transistors:

2N3904 npn (2) *

Resistors: 1/4 W unless otherwise specified

220 Ω $\pm 5\%$ (2)
1 k Ω $\pm 5\%$ (2) *
10 k Ω $\pm 5\%$ (2) *
47 k Ω $\pm 5\%$ (2)
309 k Ω $\pm 5\%$ (1) *

Capacitors:

100 μF 10 WVDC or greater (1) *
1.5 μF non-polarized (2)