

EECE2413

Electronics Lab

Department of Electrical and Computer Engineering
Northeastern University

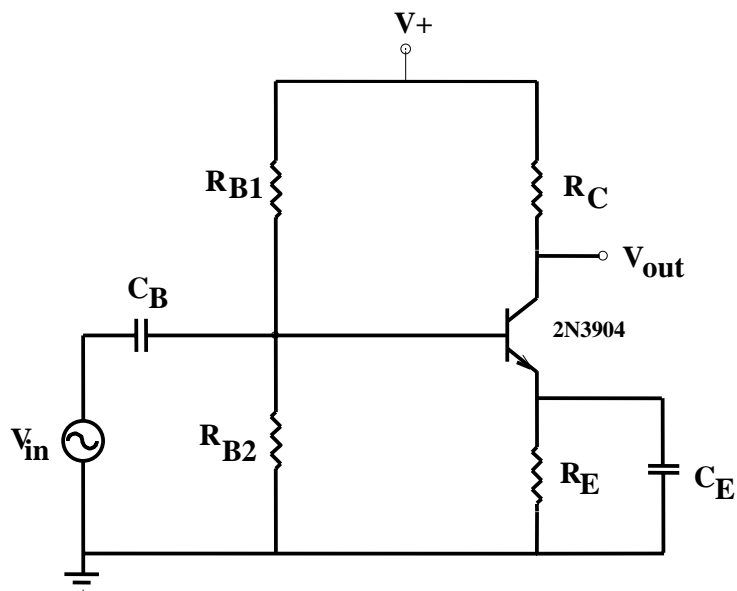

2009

Syllabus for EECE2413

Electronics Lab

Course Goals: *This lab is intended to supplement, in a practical way, the material you learn in Electronics. In each lab you will perform three different kinds of experiments commonly used by professional engineers: (1) Basic exploration of electronic devices and circuits using predefined experiments, (2) Construction of your own experiments to determine the behavior of devices and circuits, and (3) Design of electronic circuits using performance specifications. Successful completion of this lab will help you to improve these critical engineering skills.*

Corequisite: EECE2413, Electronics (Must be taken simultaneously)

Text: Lab Manuals are provided.
You must purchase a hardbound Lab Notebook for recording all lab data (for example, Roaring Spring No. 77475, about \$4.00).

Prelabs: Prelabs are designed to help you understand the lab experiment. They are due at the beginning of each lab. Make a copy of the prelab so that you can refer to it during the experiment!

Lab Reports: **Each student will write a Lab Report for each experiment.**
All lab reports are to be typed. They must be written in clear and concise English. Use the spell-checker!

Use the format described on page 4 for lab reports:

- I. Cover page (an example is attached on page 7)
- II. Introduction (a brief description of the purpose and goals of the lab)
- III. Results
 1. Experimental Methods (including circuit diagrams)
 2. Tabulated Results
 3. Calculations
- IV. Analysis
 1. Answers to questions posed in the lab manual
 2. Appropriate analysis of your results and their validity
- V. Conclusions

Late Reports: A deduction of 10% per day will be assessed to late lab reports

Grading: 25% Prelabs
65% Lab Reports
10% Lab Notebook

Note: You must hand-in your complete lab book with the last lab report. Do not rip out any of the pages.

Report Grade=Intro10%+Results40%+Analysis30%
+Conclusion20%

Absence: Make-up labs must be pre-arranged with the instructor. In the event of an illness, proper documentation must be supplied by the student

Ethics: It is a violation of the Student Code of Conduct to present for credit data taken by someone else, fabricate or alter data, or copy the laboratory reports of others.

Safety: **You must read and follow the safety rules found on page 8.**

ECE Laboratory Report Format

A Lab report should be a clear and concise presentation of engineering work you performed, and must include all relevant aspects of the lab experiment or exercise. The report must be presented in an appropriate professional format such that it could be read and understood by any technical person, even if they were not familiar with the lab. The following format guidelines must be followed for all lab reports. **Additional special instructions may be given to you by your instructor or in the lab manual for the course.**

The lab report must be prepared (typed) with a word processor. Equations and schematics can be neatly drawn by hand if you don't want to use your word processor's equation editor or drawing program. The report should include the following elements:

I. Title Page

Each report shall have a cover page (plain paper accepted) which will contain the following information: 1) Lab Title/Experiment Number, 2) Course Number and Title, 3) Instructor's Name and TA Name, 4) Name of students, 5) Date. A sample cover page is provided on page 7 of this document.

The body of the lab report consists of the following part: Introduction/Objectives, Results and Analysis, and Conclusion. Each of these sections should be introduced by a bold, left-justified heading.

II. Introduction/Objectives

This section introduces the reader to the problem you are trying to solve and guides the reader through your approach to solve the problem. In a few paragraphs a concise statement is to be made of the goal(s) and purpose(s) of the lab. It should summarize approaches adopted and methods involved in carrying out the typical sentence from the instruction/Objective might be, "We built and tested three biasing circuits to determine the advantages of each for temperature stability and sensitivity to poorly-controlled transistor characteristics such as the current gain."

The introduction may contain preliminary hand calculations that you have performed. For instance, if the circuit is an amplifier, you might use hand calculations to establish a suitable bias condition and justify the selection of initial component values based on these calculations.

Note on Technical Writing Style: Formal technical reports should always be written in the past tense ("we measured the voltage..." not "we measure voltage..."). The pronouns "we" and "our" are OK (yes, even if you did the experiment by yourself), but "I", "my", or "you" are not to be used.

III. Results and Analysis

This section can be divided into one "Result" section and one "Analysis" section, or

for multipart labs you may include subsections to discuss together the results and analysis of each part. For this second alternative, put a left-justified subheading on a separate line with a title for each part of the lab (for example, “Part 1. Biasing of Transistors”).

A. Results

In the “Results” section present all experimental output in a clear and effective manner. You can refer to steps in the “procedure” of the lab write-up in the Lab Manual, but key schematics of circuit or logic designs should be reproduced in the report. You can cut and paste a Xerox from the Lab manual into the lab report—be sure to give it a figure number and caption. This will allow you to refer to the diagram in your text, for example, “The resistor value was adjusted to achieve a balanced output as described in the lab manual, and the current through the meter A1 in Figure 1 was measured as a function of the source voltage V1.” All equipment and hardware utilized in obtaining the results of your lab work must be recorded (type, make, model, etc). This record is important for someone to repeat the work performed or simply for identifying an equipment feature that influenced your results.

Results are brought together in graphs or tables of data whenever possible. Use EXCEL, MATLAB, or other graphing program. *All graphs should be properly titled, large enough, numbered, their axis properly labeled including units, and they must have captions and numbers for easy reference.* Axis labels should contain the description of the quantity, the symbol, and the units (for example, “Diode Voltage, V (mv)”). Figures and graphs may be inserted after the page on which they are referred to (better: inserted in a Figure box on the page) or collected together at the end of the report. In either case, each figure, graph, or chart must have a figure number and a caption (example: “Fig. 3: Current vs. voltage through the diode D1 for the circuit in Figure 1 with the V1 source voltage amplitude of 100V at 60 HZ”). Hand-written figure numbers and captions are OK, but *each figure number must be referred to somewhere in the body of the text.*

Important note: The lab report is your explanation of what you did and what it means, it is not a dump of 10 pages of instrument or computer output. If you don’t comment on a figure, the assumption is that you don’t know what it means or why it is there. Output that is presented but not described in a write-up will be assumed to be incomprehensible to the student and will result in a reduced grade. A good starting point is to try to use the minimum amount of output and other supporting material to adequately document your work. If you don’t need refer to a figure, leave it out! If a figure is required, make sure you explain its significance and what conclusions can be drawn from it.

B. Analysis

In the analysis section you examine your results in light of theoretical predictions. Appropriate analysis is needed to provide comparison for evaluating your results and assessing their validity. For results of design tasks it is necessary to evaluate both the “function” as well as “performance” of your design based, respectively, on intended behavior (what it does) and design specifications (how well it is done).

Reconcile experiment and theory by identifying factors that influence your results (as quantitatively as possible) and may account for any discrepancy observed. If possible, indicate the error on your data: for example, indicate the noise level by “ $\pm 5 \mu V$ ” in your tables and put error bars on the data points in your graphs. Comparison of theory and experiment could take various forms: a composite plot of a pair of graphs-one labeled “theory” (usually a line) the other “experiment (usually discrete points), a combined table with experiment/theory entries, or an error/discrepancy figure calculated as % deviation, etc.

IV. Conclusion

The conclusion (or summary) is one or two concluding paragraphs to the project. This section describes the work you did, conclusions that you draw from the work, and what you learned from the lab. It also includes, in a descriptive way, the results obtained. A typical sentence sequence in the summary might be: “Our analysis of the circuit showed that the value of R_c with a current mirror and choosing a transistor with an Early voltage greater than 100 volts, this problem is eliminated.” You are expected to draw conclusions, identifying important or significant engineering implications, and even recommend possible applications stemming from the work done in the lab.

V. Appendices

Use appendices for program code, long printouts, or data tables that are important to verify your results but unnecessary to the flow of your report. Also include here any original sheets with data entries, circuit designs, etc.

In closing, you are encouraged before turning your report to review it as a critic and make in it last-minute revision to enhance its presentation. Remember, the report is a reflection of your ability to perform good-quality work and to communicate it to others clearly and effectively.

Northeastern University
Department of Electrical and Computer Engineering

Lab# _____

Title: _____

EECE2413

TA: _____

Team# _____

Section: _____

Authors:

Semester: _____

Date: _____

LABORATORY SAFETY RULES

To ensure safe operation in the laboratory facilities of the Electrical and Computer Engineering department, the following safety rules should be observed regarding laboratory practice. (A separate appropriate list of rules applies to the Semiconductor Processing Laboratory)

1. As AC or DC electrical power is hazardous to human life, you must exercise caution when operating electrical equipment.
2. As liquids can aggravate the danger of electric shock, all DRINKS/FOOD is prohibited from the Laboratory.
3. For user protection, all equipment is grounded via a 3-prong power plug. Do not convert to a 2-prong plug!
4. In the event a hazardous electrical defect(e.g., exposed “live”-wire) is discovered, turn-off the power and immediately alert the instructor/lab attendant.
5. For operation in the POWER Lab in the proximity of Rotating Machines(motors/generators), never wear loose clothing (ties, sleeves, chains) or long hair – as these can get caught in rotating parts.
6. For operation in the MICROWAVES Lab in the presence of Electromagnetic Radiation, the U.S.A. safety standard is:

$$\text{Power density} < 10 \text{ mW/cm}^2$$

$$\text{Energy density} < 1 \text{ mW hr/cm}^2$$

7. Never work alone – be sure others are present in the room to call for help in case of accident.
8. In the event of an accident call EMERGENCY – Ext. 3333.

Lab Director
415 Dana Research Building
Northeastern University
Boston, Massachusetts 02115
617-373-2164

Proto-Boards: Throughout this lab you will use a proto-board. Proto-boards are useful for quickly assembling circuits without soldering. The front side of the board consists of long rows of tie points that are all connected together. These rows are useful for distributing supply voltages throughout the board. Surrounded by these long rows, are columns of five tie points. Each group of five is connected under the surface as shown in the back-side view below. Integrated circuits should straddle the deep groove running along the board such that each pin of the IC is connected to a unique 5-hole tie point.

Front-side view of a proto-board showing the tie points arranged in rows and columns

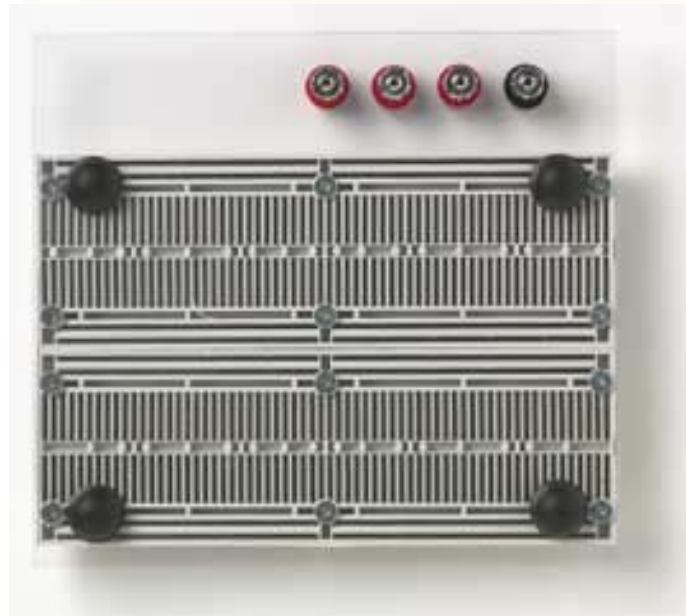

Back-side view of a proto-board showing the rows and columns of electrical connections.