

# EECE 2210 - Electrical Engineering

## Quiz 5

Prof. Charles A. DiMarzio

11 October 2021

Student Name: \_\_\_\_\_

The circuit shown is an inverting amplifier, with  $R_1 = 2\text{ k}\Omega$ ,  $R_2 = 12\text{ k}\Omega$ ,  $R_3 = 2\text{ k}\Omega$ ,  $R_L = 10\text{ k}\Omega$

1. What is the voltage gain of the amplifier?

\_\_\_\_\_

2. If we connect an ideal voltage source,  $V_{in} = 100\text{ mV}$ , to the input, what is the current from that source. Assume positive current is from left to right in  $R_1$ .

\_\_\_\_\_

3. How much power is produced by the source?

\_\_\_\_\_

4. For the same input, what is the output voltage?

\_\_\_\_\_

5. How much power is absorbed by the load?

\_\_\_\_\_

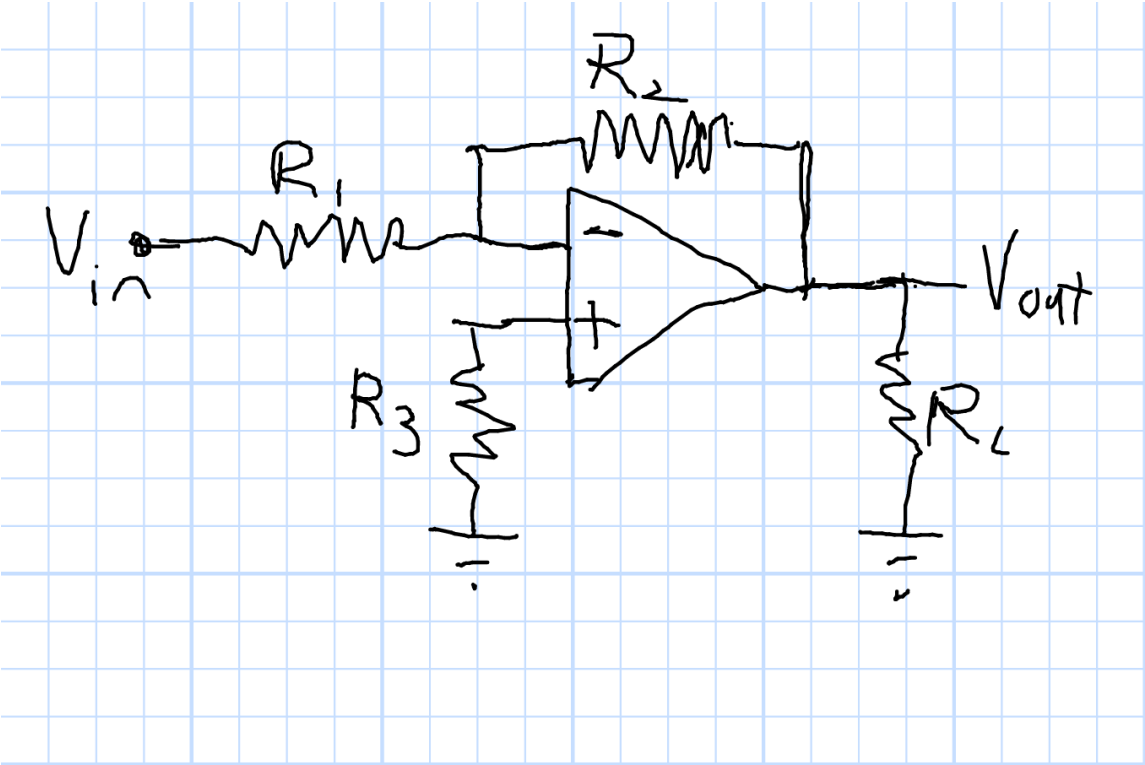

1.

$$A_V = -\frac{R_2}{R_1} = -\frac{12 \text{ k}\Omega}{2 \text{ k}\Omega} = -6.$$

2.

$$i = \frac{V_{in} - 0}{R_1} = \frac{100 \text{ mV}}{2 \text{ k}\Omega} = 50 \mu\text{A}.$$

Note that  $R_3$  doesn't matter. No current flows in it so  $V_+ = 0$ .

3.

$$P = iV = 50 \mu\text{A} \times 100 \text{ mV} = 5 \mu\text{W}.$$

4.

$$V_{out} = A_V V_{in} = -6 \times 100 \text{ mV} = -600 \text{ mV}.$$

5.

$$P = \frac{V^2}{R_L} = \frac{(-600 \text{ mV})^2}{10 \text{ k}\Omega} = 36 \mu\text{W}.$$