

Circuits and Signals: Biomedical Applications Week 13

Charles A. DiMarzio
EECE-2150
Northeastern University

Nov 2023

Week 13: Review

- Exam Details: Tue 12 Dec 10:30-12:30 in 221 Hayden
- Circuits: Voltage, Current, Power
- Transient Analysis
- Amplifiers
- Filters
- Fourier Transforms

Exam Format

- 1 Set of Short–Answer Questions
- 3 Traditional Problems
- Bring a Calculator
- Bring 2 Sheets of Notes 8.5X11 Both sides
- Allowed Time: 2 Hours
- Proctors may not know material.
- I will grade exams.

Good Practice

- Show Work Clearly
- Explain Your Reasoning for Partial Credit
- Any Doubt: Make best guess and explain
- Avoid appearance of dishonesty

Practice Exams

On the Website

Especially look at last year's exam.

Circuits

- Sources
- Resistors, Capacitors, Inductors
- KCL, KVL
- Series and Parallel
- Voltage and Current Dividers
- Node and Mesh Analysis
- Superposition
- Thévenin and Norton
- Power

Circuit Components

Devices

Resistors	Capacitors	Inductors
$v = iR$	$v = \frac{1}{C} \int i dt$ $i = C \frac{dv}{dt}$	$i = \frac{1}{L} \int v dt$ $v = L \frac{di}{dt}$
R in Ohms	C in Farads	L in Henries
	Voltage Continuous	Current Continuous
	Open to DC	Short to DC

Parallel/Series Summary

	Series	Parallel
Voltage Sources	$v = \sum v_n$	Contradictory
Current Sources	Contradictory	$i = \sum i_n$
Resistors	$R = \sum R_n$	$\frac{1}{R} = \sum \frac{1}{R_n}$
Inductors	$L = \sum L_n$	$\frac{1}{L} = \sum \frac{1}{L_n}$
Capacitors	$\frac{1}{C} = \sum \frac{1}{C_n}$	$C = \sum C_n$

Instrumentation

- Power Supply
- Multi-Meter
- Signal Generator
- Oscilloscope

Amplifiers

- OP–Amps
- Typical Circuits
- Gain, Input and Output Impedance
- Differential Amplifier, Common–Mode Gain
- Saturation

Inverting Amplifier Circuit

$I_+ = 0, I_- = 0, v_x = 0$: Virtual Ground

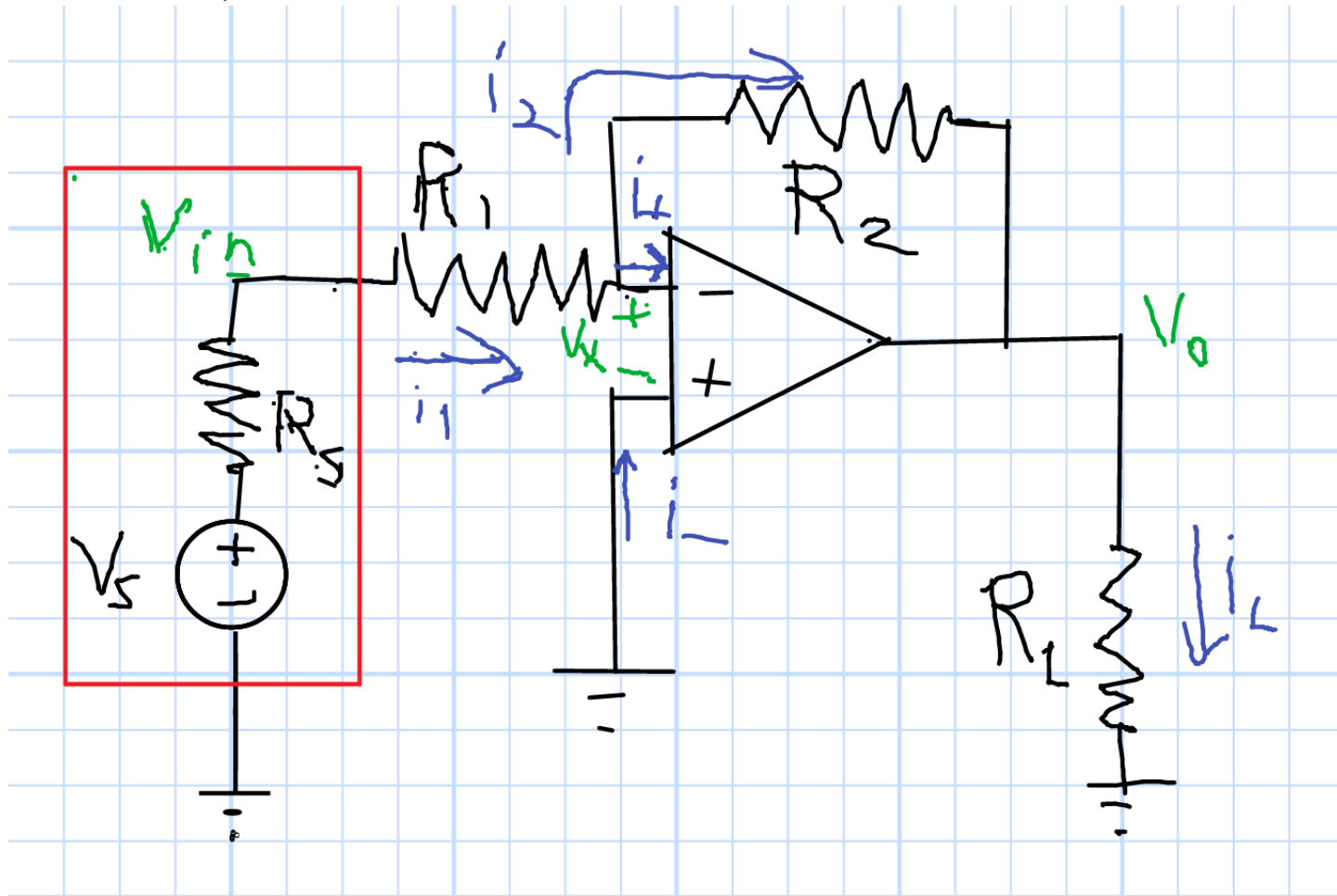

$$i_1 = i_2 \text{ so } v_o = -v_{in} \frac{R_2}{R_1} \text{ or } A_v = -\frac{R_2}{R_1}, R_{in} = R_1, R_{out} = 0$$

Digital and Analog

- Digital-to-Analog
- Analog-to-Digital
- Sampling
- Bit Depth

Time-Varying Circuits

- Transient Analysis
- Steady State Analysis
- RC Time Constant
- Differential Equations
- Boundary Conditions

Sinusoids (1)

- Complex Numbers
- Resistance and Reactance
- Eli the Ice Man
- Resistive and Reactive Power
- Filters

Sinusoids (2)

- Fourier Series
- Fourier Transforms
- Convolution

Fourier Transforms

- Time and Frequency Axes
- Real Functions of Time
- Symmetry Relationships
- Convolution Theorem

Remember

- Decibels
- RMS, Zero-to-Peak, Peak-to-Peak
- Unit prefixes from femto- to Peta-

Conclusion

- Thanks! I hope to see you in the future.
- Fundamentals: **Electronics**, Linear Systems, Electromagnetics
- Electives: **Optics for Engineers (Spring)**, **Biomedical Imaging Instrumentation (Chile Su1)**, **Design/Prototyping Optical Systems (Spring)**, More
- **Directed Study**
- **Research**
- **Capstone**
- **Anything Else**