

ECG Beat Detection Using Filter Banks

Valtino X. Afonso, *Member, IEEE*, Willis J. Tompkins,* *Fellow, IEEE*,
Truong Q. Nguyen, *Senior Member, IEEE*, and Shen Luo, *Member, IEEE*

Abstract— We have designed a multirate digital signal processing algorithm to detect heartbeats in the electrocardiogram (ECG). The algorithm incorporates a filter bank (FB) which decomposes the ECG into subbands with uniform frequency bandwidths. The FB-based algorithm enables independent time and frequency analysis to be performed on a signal. Features computed from a set of the subbands and a heuristic detection strategy are used to fuse decisions from multiple one-channel beat detection algorithms. The overall beat detection algorithm has a sensitivity of 99.59% and a positive predictivity of 99.56% against the MIT/BIH database. Furthermore this is a real-time algorithm since its beat detection latency is minimal. The FB-based beat detection algorithm also inherently lends itself to a computationally efficient structure since the detection logic operates at the subband rate. The FB-based structure is potentially useful for performing multiple ECG processing tasks using one set of preprocessing filters.

Index Terms— Electrocardiography (ECG), ECG beat detection, filter bank (FB), multirate digital signal processing.

I. INTRODUCTION

A. ECG Processing Tasks

VARIOUS signal processing algorithms have been developed to process the electrocardiogram (ECG) [1]–[7]. Detecting QRS complexes in the ECG is one of the most important tasks that need to be performed. This stage is crucial in basic ECG monitoring systems and also is important for all other ECG processing applications. Enhancement of the ECG is also important in a stress test [6], [7]. The stress ECG is prone to various types of noise, and it is important to reduce the noise without distorting the morphology of the ECG. Arrhythmia classification is another important task in interpretive systems which provide a diagnostic classification of the ECG. Another useful processing task is a noise alert algorithm which determines the fidelity of the ECG by indicating the level and type of noise in the signal. Fig. 1 shows four of the many tasks that must be performed on the ECG in different applications.

B. Beat Detection Algorithms

A crucial part of any ECG processing algorithm is beat detection. References [2] and [3] represent original works on

Manuscript received July 19, 1996; revised August 31, 1998. This work was supported by a grant from Burdick Inc., Milton, WI. *Asterisk indicates corresponding author*

V. X. Afonso is with the Endocardial Solutions, Inc., Saint Paul, MN 55108 USA.

*W. J. Tompkins is with the Department of Electrical and Computer Engineering, University of Wisconsin, 1415 Engineering Dr., Madison, WI 53706 USA (e-mail: tompkins@engr.wisc.edu).

T. Q. Nguyen is with the Department of Electrical and Computer Engineering, Boston University, Boston, MA 02215 USA.

S. Luo is with Spacelabs Burdick Inc., Deerfield, WI 53531 USA.

Publisher Item Identifier S 0018-9294(99)00829-0.

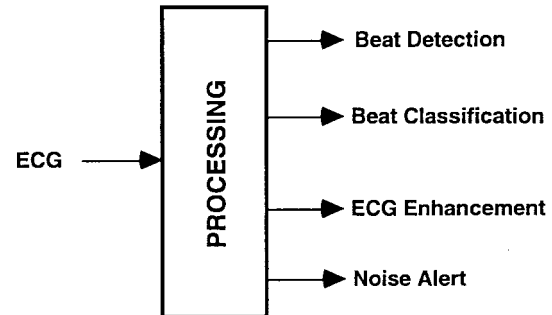

Fig. 1. Multiple processing tasks are performed on the ECG. An overall goal is to effectively accomplish these multiple tasks at a computationally efficient rate with one set of preprocessing filters.

the subject of ECG beat detection. Beat detection algorithms typically incorporate a preprocessing filter which decomposes the ECG into a signal which maximizes the signal-to-noise ratio (SNR) of the QRS complex [3]. A nonlinear processing stage and moving window integrator (MWI) are used to compute a signal that emphasizes the energy of the QRS complex. Beat detection logic incorporates a history of signal peaks and noise peaks which are used to establish signal and noise levels, respectively. A threshold is then used to decide if an incoming peak is due to the QRS complex or noise. If a period of time corresponding to the average heartbeat interval elapses without a beat detection, a “search-back” strategy is used to check the ECG again for the presence of a beat [3], [4].

Algorithms such as the one described operate at the same rate as the input ECG. The filters used are designed to optimize the SNR of the QRS complex [3], [8]. Information from other frequency components of the ECG are filtered out and cannot be incorporated into the beat detection logic. Thus, the preprocessing filters are not useful to other ECG processing tasks. The search-back strategy sometimes results in a beat detection latency time of more than one heartbeat interval. This is not useful when immediate indication of the occurrence of a beat is needed.

C. Filter Bank (FB) Strategy

Recent and extensive work on the design and use of FB’s is presented in the literature [9]–[11]. Fig. 2 shows that a FB contains a set of analysis filters which decompose the bandwidth of the input signal into subband signals with uniform frequency bands. The subbands can be downsampled since the subband bandwidth is much lower than that of the input signal. Processing can be performed on the subbands according to a specific application. Moreover, the subbands may be reconstructed by a set of synthesis filters which will

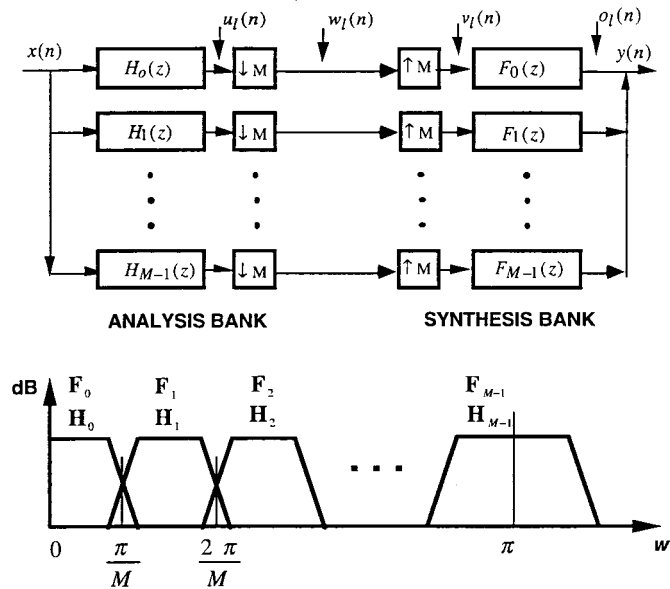

Fig. 2. A FB contains a set of analysis filters which decompose the input signal into subbands with uniform bandwidths. The filters can be designed to reconstruct the subbands to result in a perfect reconstruction of the input signal. Ideal magnitude responses of the filters are shown.

perfectly reconstruct the input signal. Fig. 2 shows the ideal magnitude responses of the filters.

The subbands provide information from various frequency ranges and, thus, it is possible to perform time and frequency-dependent processing of the input signal. Because the subbands are downsampled, processing can occur at a lower rate than the input sampling rate. References [6] and [7] show how to process the subbands to reduce noise in the higher frequency subbands outside the QRS complex. The rationale in this is that there are no high frequency components of interest outside the QRS complex. This noise removal strategy is potentially useful to enhance the stress ECG.

Thus, the FB allows time and frequency-dependent processing to be performed at a computationally efficient rate to analyze the ECG.

D. Objective

An overall goal is to develop one set of preprocessing filters which is useful in a variety of tasks for ECG processing, see Fig. 3. Furthermore, as we will explain in this paper, the FB-based approach inherently leads to a multirate strategy for processing the ECG. Thus, processing tasks like ECG beat detection can be performed at a lower rate than the input sampling rate and this leads to the computational efficiency of the FB-based strategy. ECG beat detection is an important component of many tasks in ECG processing and, thus, in this paper we focus on an ECG beat detection algorithm using a FB-based approach for preprocessing.

E. Outline

Section II reviews the theory and design of FB's [9], [10]. We explain certain properties of FB's which are useful for ECG digital signal processing. Section III explains the

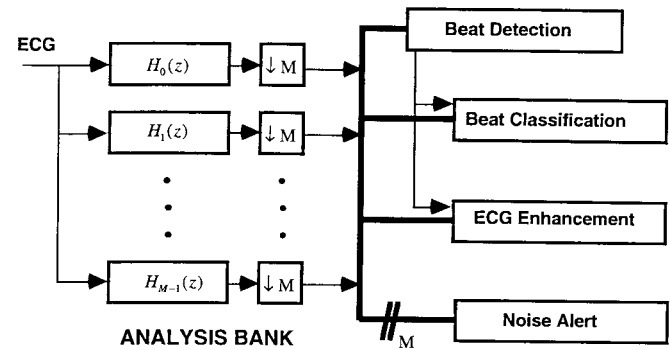

Fig. 3. One set of preprocessing filters decompose the ECG into subbands with uniform bandwidths. Time and frequency-dependent processing can be performed on the subbands to accomplish multiple tasks at the reduced subband rate.

preprocessing operations performed on the ECG, and section IV explains the beat detection logic. Section V describes the methods used to implement and test the algorithm, and Section VI presents performance results of the beat detection algorithm on the MIT/BIH database. Section VII discusses the algorithm performance and advantages of the FB-based approach to ECG processing.

II. FB THEORY

A. The FB Strategy

Fig. 2 shows that the FB contains a set of analysis and synthesis filters. The analysis filters decompose an incoming signal into specific frequency bands or subbands. Processing can be performed on each subband independently. The set of synthesis filters can then combine the processed subbands to result in a processed version of the input signal. Thus, a FB-based algorithm involves decomposing a signal into frequency subbands, processing these subbands according to the application at hand, and then sometimes reconstructing the processed subbands. Fig. 2 shows a general block diagram of a FB-based algorithm and ideal magnitude responses of the filters.

Many scenarios deal with signals which contain specific energy distributions in the frequency domain. For example, with regard to the ECG, a significant proportion of the energy from the QRS complex extends to a frequency of 40 Hz, and even more if the Q, R, and S waves have very sharp morphologies. The P and T waves, in general, have a significant proportion of their energy only up to 10 Hz.

A heartbeat, whether originating in the sino-atrial node (SA), a supraventricular site, the junctional node, or one or two ectopic sites in the ventricle, results in a QRS complex which generally has a significantly higher frequency content than that of the T and P waves. A QRS complex originating from an impulse in the SA node, will have a “sharp” morphology in the time domain and hence significant energy in the higher frequency subbands. A QRS complex resulting from an ectopic site in the ventricles will have a “rounded” morphology and not as significant energy in the higher subbands, and in fact a stronger energy in the lower subbands.

Thus, a strategic approach to detecting heartbeats is to analyze different subbands of the ECG, rather than just the output of one filter which maximizes SNR of the QRS as in [3].

B. FB Block Diagram

This section reviews some of the theory of FB's explained in [9]. As shown in Fig. 2 a FB contains M analysis and M synthesis filters, each of length L . The analysis filters $H_l(z)$, $l = 0, 1, \dots, M-1$, bandpass the input signal $X(z)$ to produce the subband signals $U_l(z)$

$$U_l(z) = H_l(z)X(z) \quad l = 0, 1, \dots, M-1. \quad (1)$$

The effective bandwidth of $U_l(z)$ is π/M and, thus, it can be downsampled to reduce the total rate. The downsampling process keeps one sample out of M samples. The downsampled signal $W_l(z)$ is

$$W_l(z) = \frac{1}{M} \sum_{k=0}^{M-1} U_l(z^{1/M} W^k) \quad l = 0, 1, \dots, M-1 \quad (2)$$

where $W = e^{-j(2\pi/M)}$. The subbands $U_l(z)$ and $W_l(z)$ are bandpassed versions of the input and also $W_l(z)$ has a lower rate than $U_l(z)$. The filtering process can be efficiently done at $1/M$ the input rate by taking advantage of the downsampling. This process is referred to as the polyphase implementation and contributes to the computational efficiency of the FB-based algorithm [9].

The upsampling block performs an upsampling operation by inserting $M-1$ zeros after each of its inputs to result in the subband signal, $V_l(z)$

$$V_l(z) = W_l(z^M) = \frac{1}{M} \sum_{k=0}^{M-1} H_l(zW^k)X(zW^k) \quad l = 0, 1, \dots, M-1. \quad (3)$$

The synthesis filters $F_l(z)$, then operate on the upsampled subband signals $V_l(z)$, to result in $O_l(z)$. Since at least $M-1$ in M data points are zero in $V_l(z)$, at most L/M coefficients in the synthesis filters overlap nonzero data in $V_l(z)$ and the synthesis filters can be operated efficiently

$$O_l(z) = F_l(z)V_l(z) \quad l = 0, 1, \dots, M-1. \quad (4)$$

The subband signals $O_l(z)$, can then be algebraically added point by point to result in the output $Y(z)$

$$Y(z) = \sum_{l=0}^{M-1} O_l(z) = \frac{1}{M} \sum_{k=0}^{M-1} X(zW^k) \sum_{l=0}^{M-1} H_l(zW^k)F_l(z). \quad (5)$$

The above can be rearranged as follows:

$$Y(z) = \sum_{k=0}^{M-1} T_k(z)X(zW^k) \quad (6)$$

where

$$T_k(z) = \frac{1}{M} \sum_{l=0}^{M-1} H_l(zW^k)F_l(z) \quad k = 0, 1, \dots, M-1. \quad (7)$$

Thus, the output $Y(z)$ is a combination of many shifted versions of the input $X(z)$.

This overall structure of the FB can be used to implement many ECG processing tasks, see Fig. 3. References [6] and [7] show that the subbands can be processed to reduce the level of noise present in the stress ECG. In the beat detection algorithm we use the subbands to extract features that are indicative of the QRS complex. The FB should have certain properties which are necessary for ECG processing.

C. Aliasing and Imaging

Equation (6) shows that $Y(z)$ contains shifted components (or aliased terms) of the input signal $X(z)$. These aliasing components are introduced by the downsampling and upsampling processes because of the nonideal nature of the analysis and synthesis filters. Aliasing can be removed for any arbitrary input $X(z)$, if and only if [9]

$$T_k(z) = 0 \quad k = 1, \dots, M-1. \quad (8)$$

If the aliasing terms are removed then (6) becomes

$$Y(z) = T_0(z)X(z). \quad (9)$$

D. Magnitude and Phase Distortion

When all the aliasing terms are removed according to (8), then the output is related to the input by (9). The distortion function $T_0(z)$ is given by

$$T_0(z) = \frac{1}{M} \sum_{l=0}^{M-1} H_l(z)F_l(z). \quad (10)$$

If $T_0(z)$ has a constant magnitude response and a linear phase then the FB has no magnitude or phase distortion.

E. Perfect Reconstruction

A FB which does not introduce aliasing distortions, nor magnitude or phase distortions is known as a perfect reconstruction (PR) FB. Thus, for a PR FB, $T_0(z)$, is a pure delay, and all the aliasing terms are canceled. The output is related to the input by

$$y(n) = cx(n-k) \quad (11)$$

where k is the system delay, and c is a constant gain factor.

The reason for using the PR property of FB's is that the overall goal is to develop one set of filters which is useful for multiple ECG processing tasks; see Fig. 3. ECG beat detection does not require reconstruction at the output of the FB. For this application, only decomposition of the input into frequency subbands is of interest. However, simultaneous processing of the subbands could be performed for other ECG processing tasks, such as ECG enhancement [6] and [7].

ECG enhancement requires reconstruction of the processed subbands. Thus, aliasing, and magnitude and phase distortions must be eliminated. This is the reason why the design of the FB should include the PR property.

F. Linear Phase

For ECG beat detection it is important to have a deterministic relationship between fiducial points in the input ECG and the subband signal. This requires that each of the analysis filters have linear phase. The linear phase requirement when designing the FB ensures that all frequencies in the input signal will have the same *sample delay* through the analysis filters. It is then possible, for example, to determine the exact location of the R wave in the input ECG signal, and other fiducial points from analysis of the subbands.

This linear phase requirement on each filter in the FB should be distinguished from the linear phase property of the whole FB system. In (9), $T_0(z)$ can have linear phase even though each of the analysis and synthesis filters have nonlinear phase. Thus, the FB system output can have no phase distortion with respect to the input (i.e., a *linear phase* FB) even though each of the analysis and synthesis filters have *nonlinear* phase frequency responses. However, for ECG processing it is important that each of the analysis and synthesis filters have a linear phase response.

III. PREPROCESSOR

A. Analysis Filters

Fig. 4 shows the magnitude responses of the filters used in the 32-channel FB. Each filter has 64 coefficients and is designed using the technique in [12]. The filters are FIR and result in a FB which does not have any aliasing, nor magnitude and phase distortions (i.e., it is a PR FB). Furthermore each of the filters have linear phase and a bandwidth of 5.6 Hz. The filters are operated once every 32 samples because of the downsampling process. The downsampling process results in many subbands to be computed at the cost of one filter and efficiently computed using the polyphase implementation [9].

The downsampled signal $W_l(z)$ is given in (2) and is repeated here for convenience

$$\begin{aligned} W_l(z) &= \frac{1}{M} \sum_{k=0}^{M-1} U_l(z^{1/M} W^k) \\ &= \frac{1}{M} \sum_{k=0}^{M-1} H_l(z^{1/M} W^k) X(z^{1/M} W^k) \\ & \quad l = 0, 1, \dots, M-1. \end{aligned} \quad (12)$$

Fig. 5 shows illustrative examples of $W_l(z)$ for three of the subbands for a value of M of 32 when input is a normal sinus rhythm ECG. Note that $W_l(z)$ has a lower sampling rate (11.2 Hz for this example) than the input ECG sampling rate of 360 Hz.

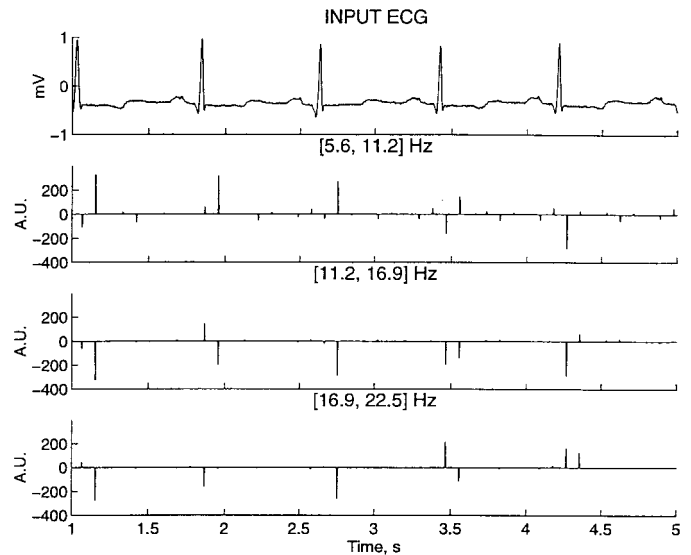

Fig. 5. The input ECG is decomposed into subbands with uniform bandwidth. The second plot shows the subband $W_1(n)$ which corresponds with the [5.6, 11.2] Hz frequency range. Features such as the sum-of-absolute values of the subbands which are indicative of the QRS complex are used in the beat detection logic.

B. Features

A variety of features which are indicative of the QRS complex can be designed by combining subbands of interest from $l = 0, 1, \dots, M-1$. For example a sum-of-absolute values feature P_1 can be computed using subbands 1, 2, and 3.

$$P_1 = \sum_{l=1}^3 |W_l(z)|. \quad (13)$$

P_1 has a value which corresponds to the energy in the frequency band [5.6, 22.5] Hz. Similarly, P_2 and P_3 can be computed using subbands {1, 2, 3, 4}, and {2, 3, 4}, respectively, and these values are proportional to the energy in their respective subbands.

A sum-of-squares feature P_4 can be computed using

$$P_4 = \sum_{i=1}^3 (W_i(z))^2 \quad (14)$$

and P_5 and P_6 can be similarly computed using subbands {1, 2, 3, 4}, and {2, 3, 4}, respectively.

These features have values which are proportional to the energy of the QRS complex. Fig. 6 shows an illustrative example of P_1 which peaks near the QRS complex. Heuristic beat detection logic can be used to incorporate some of the above features which are indicative of the QRS complex.

IV. BEAT DETECTION LOGIC

A. Overview

Fig. 7 gives an overview of the sequential levels in the beat detection algorithm. The goal of the detection algorithm is to maximize the number of true positives (TP's), while keeping the number of false negatives (FN's) and false positives (FP's)

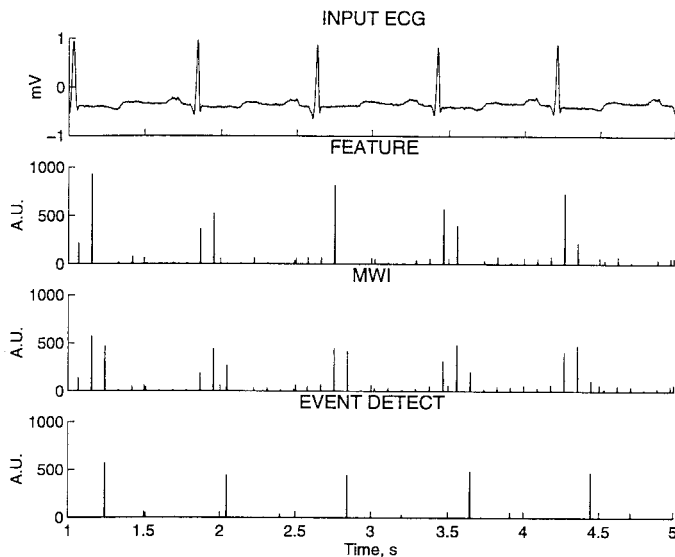

Fig. 6. The plots above show (from top to bottom) the ECG, computed feature, MWI output, event detector output. The event detector flags an event when a peak occurs in the output of a MWI operating on feature P_1 . The beat detection process occurs at the subband rate instead of the input ECG rate.

to a minimum. Since it is not possible to arrive at this goal using one simple detector, multiple detectors with complementary FN's and FP's performances are simultaneously operated and the results of each fused together to arrive at an overall decision. The advantage of this strategy is that multiple features which are indicative of the QRS complex can be used to detect beats.

B. One-Channel Detection Block

A one-channel beat detection block incorporates components similar to that in [3] (see Fig. 8). As explained above a feature which correlates with the energy in certain subbands of the ECG can be computed. This feature is input to a MWI which averages two samples at the downsampled rate. Signal (noise) values are stored when a feature is detected as a signal (noise) peak. A signal (noise) level is estimated by computing the mean of the previous signal (noise) values. The detection strength D_s of an incoming feature (e.g., P_1, P_2, \dots, P_6) is determined by comparing with the signal and noise levels (S_L and N_L , respectively)

$$D_s = \frac{P - N_L}{S_L - N_L}. \quad (15)$$

If a feature's value is less than N_L then D_s is limited at 0, and if it is above S_L then D_s is limited to one.

When a feature has a D_s greater than a specified threshold (preset between zero and one) it is classified as a signal peak and the signal history is updated with the feature's value. If the feature has a D_s smaller than the threshold it is classified as a noise peak and the noise history is updated with the feature's value.

This strategy is similar to that in [3] however more than just noting the "greater-or-less-than" status of a feature with respect to a threshold, we note the D_s indicating the "membership" of the incoming feature as a signal or noise peak. A

detection strength close to one indicates a greater possibility that the current peak is a beat, whereas a detection strength close to zero indicates a greater possibility that the current peak is a noise peak.

This detection strength parameter is useful in the overall beat detection logic since it enables the possibility to fuse data (beat detection status) from multiple one-channel detection blocks.

C. Levels

Level 1: The first level (see Figs. 6, 7) determines candidate beats by detecting peaks in the output of a MWI on feature P_1 . A peak detection algorithm detects a peak when there is an inflexion point in the output of the MWI. The feature value itself is not compared to any threshold and a peak is the only requirement to trigger an event. This level, thus, detects most of the true beats (i.e., has a few FN's) but also very often incorrectly detects the presence of a beat (i.e., noise peaks and has many FP's).

This level, thus, serves as an "event detector," and is used to trigger further logic to eliminate FP's introduced here. This level is designed to have few FN's but it limits the theoretical best FN rate possible for the overall beat detection algorithm. Since this level operates at the downsampled rate of the FB it contributes to the computational efficiency of the algorithm.

Level 2: This level, as shown in Figs. 7 and 9, has 2 one-channel detection processes (**Chan₁** and **Chan₂**) operating simultaneously. Both channels use feature P_2 in their respective MWI's, however the preset thresholds are different. **Chan₁** has a low threshold ($T_1 = 0.08$) and **Chan₂** has a high threshold ($T_2 = 0.70$). When level 1 triggers an event the output in the MWI's of each of **Chan₁** and **Chan₂** are compared with their respective signal and noise levels. The signal (and noise) levels in each channel are computed from the signal (and noise) history of their respective channels. Each channel computes its own detection strength and compares with their respective thresholds to result in two simultaneous (and possibly different) classifications of the current event as a beat or noise. When a channel detects a beat (or noise peak) its own signal (or noise) history is updated irrespective of the detection status from the other channel.

In a one-channel beat detection algorithm, the threshold value determines the classification of an incoming feature as a signal peak or noise peak. A low threshold will result in noise peaks being classified as a beat, and the feature value updated in the signal history. This will result in an inaccurate estimated signal level. However the noise history is updated accurately since the low threshold does not allow signal peaks to be incorrectly detected as noise. Similarly a high threshold will incorrectly result in some signal peaks being classified as noise and updated in the noise history. This will incorrectly raise the noise level and affect future beat detections. However in this scenario the signal history is updated accurately since beat detections using a high threshold are most likely correct.

This level, thus, operates two one-channel beat detection blocks which have complementary FN and FP detection rates. **Chan₁** generates a few FN's but many FP's and **Chan₂** generates many FN's but a few FP's.

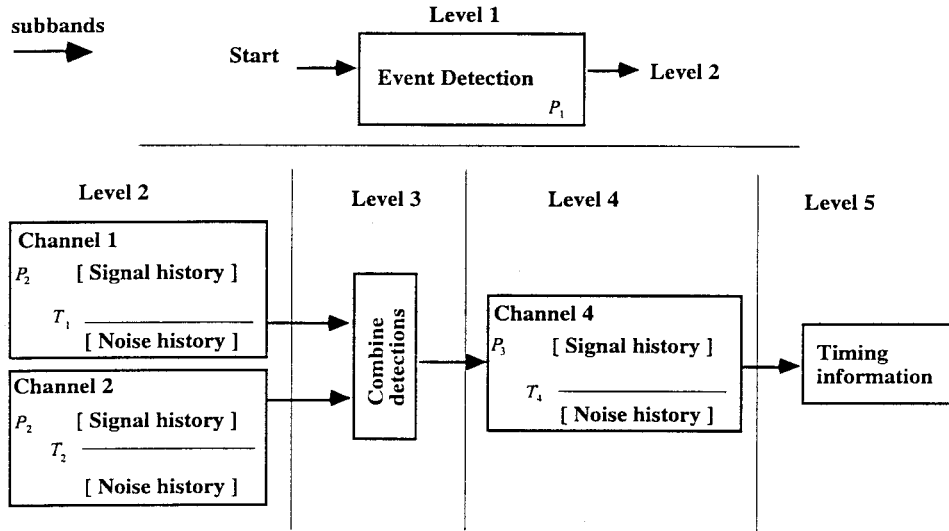

Fig. 7. The overall beat detection algorithm consists of sequential levels of beat detection channels incorporating multiple features from the subbands of the FB. Channel 1 and Channel 2 implement ECG beat detection using the same feature P_2 but with different thresholds.

Level 2 is operated only when Level 1 detects an event. Computations of the features, the MWI, and signal and noise levels operate at the reduced FB rate and this contributes to the overall computational efficiency of the beat detection algorithm.

Level 3: This level fuses the beat detection status from each of the 2 one-channel detection algorithms in level 2 by incorporating a set of if-then-else rules. The rules incorporate the fact that the 2 one-channel detection blocks have complementary detection rates. There are four possible cases to design rules for. If both channels indicate a beat then the output of level 3 classifies the current event as a beat. Since **Chan₂** uses a high threshold in its detection logic, it generates few FP's and, thus, beat detection is very accurate.

If both channels indicate not-a-beat then the output of level 3 is that the current event is not a beat. Since the threshold used in **Chan₁** is very low, it has very few FN's, and more than likely a beat did not occur in reality.

If **Chan₁** indicates not-a-beat and **Chan₂** indicates a beat, then the output is classified as a beat. However, this scenario does not occur since, the threshold used in **Chan₁** is very low, and the same feature is used in **Chan₂**. A beat detected by **Chan₂** more than likely got detected in **Chan₁**.

If **Chan₁** indicates a beat and **Chan₂** indicates a not-a-beat, then the detection strengths $D_{s_i}, i = \{1, 2\}$, from each channel are compared. **Chan₁** generates many FP's but **Chan₂** generates many FN's. The normalized detection strength $\Delta_i, i = \{1, 2\}$, which indicates which decision was "stronger," can be compared to favor the channel with the stronger decision.

The detection logic can be summarized as follows:

Chan₁	✓	×	×	✓
Chan₂	✓	✓	×	×
output	✓	✓	×	$\Delta_1 ? \Delta_2$

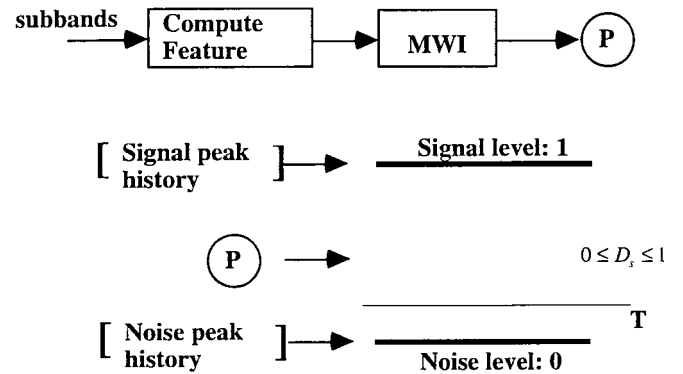

Fig. 8. A one-channel detection block computes a feature from the subbands which is indicative of the QRS complex. Signal and noise levels together with a threshold determine the status of the event as a beat or not-a-beat. The detection strength D_s indicates how close the event is to the signal (1) or noise (0) level.

where

$$\begin{aligned} \Delta_1 ? \Delta_2: & \text{ if } \Delta_1 > \text{ then } \surd \text{ else } \times \\ \Delta_1 &= (D_{s_1} - T_1) / (1 - T_1) \\ \Delta_2 &= (T_2 - D_{s_2}) / T_2 \\ (\surd: & \text{ a-beat; } \times: \text{ not-a-beat}) \end{aligned}$$

This data-fusing logic incorporates the possible range of values [0,1] of the detection strength from each one-channel detection block and fuses it based on heuristic rules. As with the other levels in the overall detection algorithm, this level operates at the subband rate of the FB.

Level 4: This level incorporates another one-channel detection block (similar to Fig. 8) and uses feature P_3 as the input to the MWI. If a beat is detected in level 3, the signal history is updated and the detection status from this level is that the current event is a beat. If level 3 did not classify the current event as a beat, the detection strength of the one-

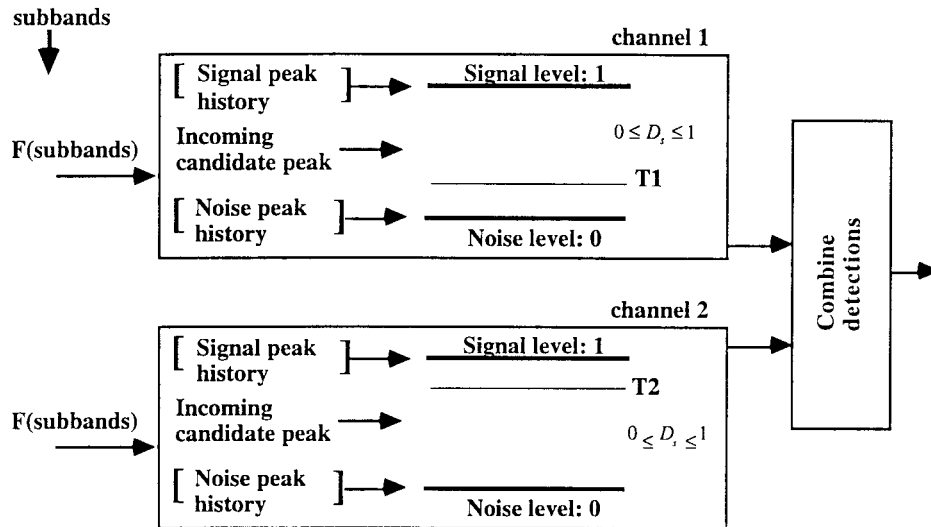

Fig. 9. Channel 1 generates many FP's, and channel 2 generates many FN's due to the strategic choice of thresholds. Decisions from 2 one-channel beat detection algorithms are combined to reduce the number of FP's and FN's.

channel detection block is computed and compared with the threshold ($T_4 = 0.30$ for this block). If the detection strength is greater than the threshold a beat is indicated and the signal history is updated. If the detection strength is less than the threshold the noise history is updated and the detection status from this level is not-a-beat.

This level reduces FN's (events which were inaccurately missed as beats by level 3). The beat detection rates after level 3 are higher than those from the detections in level 2. Since the signal and noise levels in the one-channel detection block of level 4 use detection rates from level 3, the signal and noise level estimates are more accurate than the signal and noise levels estimated in the one-channel detection blocks of level 2. This leads to improved detection rates.

Level 5: The previous levels do not incorporate any timing information in the decision logic. Level 5, thus, includes decision logic to eliminate possible false detection during the refractory period. However this is not a complete blanking of a beat during the refractory period, but rather a partial blanking.

If a beat was detected during the refractory period (with reference to the previous beat detection) and also had a minimal detection strength in level 4 ($D_{s4} \leq 0.05$), then the status of the event is changed from a-beat to not-a-beat. Note that since level 4 only checks for FN's, it is possible for an event to be classified as a beat in level 3 and not get checked with the threshold in level 4.

V. METHODS

A. ECG Database

The MIT/BIH [13] was used to determine parameters' values in the algorithm. Testing was performed on channel 1 of the database. The statistical software included in the MIT/BIH database was used to test the beat detection algorithms. Reported statistics include beat detections beginning after 5 min

in each record which is the default setting of the software included in the database.

Two benchmark parameters are used to compare detection algorithms. The sensitivity and positive predictivity of the beat detection algorithm are computed by [14]

$$Se = \frac{TP}{TP + FN} \quad (16)$$

$$+P = \frac{TP}{TP + FP} \quad (17)$$

where TP is the number of true positives, FN the number of false negatives, and FP the number of false positives. The sensitivity Se reports the percentage of true beats that were correctly detected by the algorithm. The positive predictivity $+P$ reports the percentage of beat detections which were in reality true beats.

B. One-Channel Beat Detection

The effect of the threshold values and the type of features on the beat detection accuracy were studied. The beat detection accuracy of a one-channel detection block was computed using various threshold values, and both the sum-of-square and sum-of-absolute features discussed above. From this analysis the threshold values can be strategically chosen to provide beat-detection blocks with complementary detection rates (one with minimal FP's, and the other with minimal FN's).

C. Implementation

The FB-based beat detection algorithm was implemented using the C and MATLAB® programming languages. 32 analysis and 32 synthesis filters were designed using a technique from [12]. The overall beat detection algorithm required approximately 9 s to analyze one half-hour record of the MIT/BIH database on a HP 715/80 workstation.

VI. RESULTS

A. One-Channel Beat Detection

Beat detection performance for a one-channel beat detection block was studied using the MIT/BIH database for various features and threshold values. Based on these preliminary studies we noted that, in general, the sum-of-square features generate less FP's (and more FN's) for the same threshold value than the sum-of-absolute features. This fact may be useful in a beat detection algorithm which uses multiple, complementary features such as these. Two threshold values were chosen to result in complementary beat detection rates for the 2 one-channel blocks in level 2.

B. Overall Beat Detection

Table I reports the number of FP's and FN's for each record in the database. The overall sensitivity of the algorithm is 99.59 percent (374 FN's) and the positive predictivity is 99.56 percent (406 FP's). Record 108 had 121 of the total 406 FP's. This record is very noisy and the SNR is very low. The analysis filters, peak detector and MWI's in the FB contribute to a beat detection latency of about 266 ms. Some records in the database (e.g., 100) have a beat in the last 266 ms of the record and records like this contribute to a few of the FN's. We do not correct for this in the reported statistics since it is important to use the default settings in the statistical software when comparing different beat detection algorithms.

VII. DISCUSSION

A. Choice of FB

In Section II, we explained that it is important that the FB used to process the ECG have certain characteristics. The analysis and synthesis filters should have linear phase. Linear phase ensures that the fiducial points in the ECG, such as the R wave, have the same sample delay through all the filters. The perfect reconstruction property was also incorporated into the design of the FB because an overall goal is to develop one set of filters to accomplish multiple ECG processing tasks. Stress ECG enhancement requires processing of the subbands and then reconstruction at the output. We presented a FB-based stress ECG enhancement in [6] and [7] using the same FB as the one used for the beat detection algorithm in this study. It is also important that the filters have good stop band attenuation.

The design of FB's which meet these compromising characteristics is challenging [9]–[12]. Existing FB design methods which meet the above characteristics result in analysis and synthesis filters with uniform filter bandwidths. Thus, in this study the analysis filters used to preprocess the ECG for beat detection have uniform filter bandwidths.

The choice of the number of channels in the FB is also dependent on the FB design method. Some FB design algorithms presume a power-of-two number of channels, and others require an even number of channels. Based on preliminary studies we performed with different FB design methods ([9]–[12]), the required FB properties for ECG processing, and the sampling rate of the ECG in the MIT/BIH database of 360 Hz, we decided to use a 32-channel FB. This resulted in

subbands of approximately 5.6-Hz bandwidth for the 360-Hz sampled data in the MIT/BIH database.

Modifications of the ECG beat detection algorithm for use with different sampling rates should incorporate a FB which results in subbands of about a 5-Hz bandwidth. Future work should study other FB design methods which result in lower side lobe attenuation, and analysis filters with nonuniform bandwidths.

B. Computational Efficiency

Since the subbands in the FB are downsampled, processing can be performed at the subband rate. Thus, the beat detection algorithm occurs at the downsampled rate. The components of the one-channel detection block such as the feature computation, MWI, and peak detector are operated at a lower rate than the input sampling rate of the ECG. The FB, thus, enables the analysis of multiple frequency bands very efficiently.

C. Detection Latency

The challenge with *real-time* algorithms is to output beat detections as soon as possible after the beat. This requires the beat detection algorithm to be computationally efficient and the detection logic to have minimal latency.

Many beat detection algorithms have been reported in the literature [3], [4]. Most of these algorithms incorporate a search-back strategy to correct for FN's. A search-back algorithm is activated when no beat detection has occurred in a time interval corresponding to more than the average RR interval. This strategy may result in a significant delay before a beat is detected. The search-back technique may require one or two extra beats to occur before the actual detection of the beat in question occurs. A search-back algorithm could be categorized as a real-time or on-line algorithm, depending on the application. An on-line algorithm performs beat detection using a buffer of approximately 10–20 s of the ECG. Thus, on-line algorithms may require many beats to occur before the beat in question is detected.

Other beat detection algorithms operate on ECG's that have been acquired and collected previously. These algorithms, categorized as *off-line*, scan the ECG many times back and forth to detect beats. This type of beat detection algorithm is relatively useless in real-time monitoring of patients.

The FB-based algorithm presented in this paper has minimal latency in detecting beats and is computationally efficient. It can, thus, be categorized as a real-time beat detection algorithm. Beat detection accuracy typically improves from real-time to off-line algorithms. Even so, the real-time FB-based algorithm has rates comparable to other algorithms reported in the literature.

D. Additional Logic for Improvement

Further improvements to the beat detection algorithm may be easily achieved by incorporating more features of frequency components of the ECG and adding further levels of detection logic. The analysis filters of the FB decompose the bandwidth of the input ECG into subbands of uniform frequency bandwidth. It is, thus, possible to incorporate other features such

TABLE I
 FILTER-BANK-BASED BEAT-DETECTION PERFORMANCE ON MIT/BIH DATABASE

Tape No.	TP	FP	FN	Se (%)	+P (%)
100	1901	0	1	99.95	100.00
101	1523	2	0	100.00	99.87
102	1820	1	1	99.95	99.95
103	1728	0	1	99.94	100.00
104	1849	21	8	99.57	98.88
105	2139	53	16	99.26	97.58
106	1682	3	14	99.17	99.82
107	1783	8	1	99.94	99.55
108	1425	121	55	96.28	92.17
109	2088	3	11	99.48	99.86
111	1773	0	3	99.83	100.00
112	2111	6	0	100.00	99.72
113	1505	4	1	99.93	99.73
114	1601	3	3	99.81	99.81
115	1636	0	1	99.94	100.00
116	1994	3	23	98.86	99.85
117	1283	1	1	99.92	99.92
118	1916	17	0	100.00	99.12
119	1661	1	0	100.00	99.94
121	1557	5	3	99.81	99.68
122	2054	0	0	100.00	100.00
123	1269	0	0	100.00	100.00
124	1366	1	1	99.93	99.93
200	2165	17	3	99.86	99.22
201	1514	4	7	99.54	99.74
202	1864	3	7	99.63	99.84
203	2420	39	61	97.54	98.41
205	2196	0	5	99.77	100.00
207	1591	19	1	99.94	98.82
208	2394	8	43	98.24	99.67
209	2517	4	1	99.96	99.84
210	2155	3	49	97.78	99.86
212	2284	1	1	99.96	99.96
213	2695	0	5	99.81	100.00
214	1875	1	3	99.84	99.95
215	2792	0	3	99.89	100.00
217	1840	3	5	99.73	99.84
219	1773	0	0	100.00	100.00
220	1694	0	0	100.00	100.00
221	2015	0	5	99.75	100.00
222	2112	4	4	99.81	99.81
223	2186	2	13	99.41	99.91
228	1697	32	6	99.65	98.15
230	1859	2	0	100.00	99.89
231	1278	0	0	100.00	100.00
232	1485	10	0	100.00	99.33
233	2554	1	7	99.73	99.96
234	2290	0	1	99.96	100.00
TOTAL:	90909	406	374	99.59	99.56

as the sum-of-squares of the subbands, which show a trend of generating fewer FP's than the sum-of-absolute features. The beat detection logic presented in this paper consisted of sequential levels of beat detection outcomes. More levels using different features may be added which would potentially improve the beat detection accuracy.

However, the purpose of this study is to show that beat detection can be performed with FB's which inherently are computationally efficient, and offer a unified approach to ECG processing.

The one-channel block implemented is similar to that in [3]. However this basic block is modified by computing

the decision strength of a candidate peak instead of just recording whether a beat is greater-or-less than a threshold. The decision strength ranges in value from zero to one indicating closeness to a noise or signal level, respectively. This detection strength parameter, as we demonstrated in this paper, is useful in combining beat detections from multiple channels. Furthermore, the detection strength parameter has potential in a beat detection algorithm which uses multiple ECG leads. A potential algorithm using multiple ECG leads would operate multiple single-lead, FB-based algorithms, and strategically fuse detection parameters (such as the detection strength) to arrive at an overall detection outcome.

E. Unified Algorithm for ECG Processing

Other processing tasks can be performed using the same set of analysis and synthesis filters in the FB. References [6] and [7] present an algorithm to reduce the level of noise in the stress ECG. This processing is performed on the downsampled subbands and contributes to the computational efficiency of the system. Arrhythmia classification algorithms need to incorporate features which can discriminate between normal sinus beats and ventricular ectopic beats. Reference [5] presents a diagnostic system which computes frequency domain features to distinguish between certain arrhythmias. Similar features can be computed from the subbands in the FB, and possibly help distinguish between different beats. A potential noise alert algorithm, which indicates the fidelity of noise in the ECG, can also use features extracted from subbands. For example, the lowest subband ($[0, 5.6]$ Hz) in the FB can be used to test for the presence of low-frequency baseline wander noise present in the stress ECG. The arrhythmia classification and noise alert algorithms are part of ongoing research on this subject of FB-based ECG processing.

In each of these applications, time and frequency-dependent analysis can be efficiently performed at the subband rate. Thus, the FB-based strategy enables multiple ECG processing tasks to be performed efficiently using one set of preprocessing filters.

VIII. SUMMARY

A multirate processing algorithm incorporating FB's is described for ECG beat detection. It can be categorized as a real-time algorithm since it has a minimal beat detection latency. The beat detection accuracy of the algorithm is comparable to other algorithms reported in the literature. The algorithm is computationally efficient since the beat detection logic operates at the subband rate. Further improvements to the algorithm may be easily achieved by using more features of the frequency components of the ECG. A FB-based algorithm enables time and frequency-dependent analysis to be performed on the ECG. The FB-based algorithm provides a unified framework for other ECG signal processing tasks such as signal enhancement, noise alert, and arrhythmia classification.

REFERENCES

- [1] W. J. Tompkins, Ed., *Biomedical Digital Signal Processing: C-Language Examples and Laboratory Experiments for the IBM PC*. Englewood Cliffs, NJ: Prentice-Hall, 1993.
- [2] J. Pan, and W. J. Tompkins, "A real-time QRS detection algorithm," *IEEE Trans. Biomed. Eng.*, vol. BME-32, pp. 230-236, 1985.
- [3] P. S. Hamilton and W. J. Tompkins, "Quantitative investigation of QRS detection rules using the MIT/BIH arrhythmia database," *IEEE Trans. Biomed. Eng.*, vol. BME-33, pp. 1157-1165, 1986.
- [4] C. Li, C. Zheng, and C. Tai, "Detection of ECG characteristic points using wavelet transforms," *IEEE Trans. Biomed. Eng.*, vol. 32, pp. 21-28, 1995.
- [5] S. Barro, R. Ruiz, D. Cabello, and J. Mira, "Algorithmic sequential decision-making in the frequency domain for life threatening ventricular arrhythmias and imitative artefacts: A diagnostic system," *J. Biomed. Eng.*, vol. 11, pp. 320-328, 1989.
- [6] V. X. Afonso, W. J. Tompkins, T. Q. Nguyen, K. Michler, and S. Luo, "Comparing stress ECG enhancement algorithms: With an introduction to a filter bank based approach," *IEEE Eng. Med. and Biol. Mag.*, vol. 15, no. 3, pp. 37-44, 1996.

- [7] V. X. Afonso, W. J. Tompkins, T. Q. Nguyen, S. Trautmann, and S. Luo, "Filter bank-based processing of the stress ECG," in *Proc. Annu. Int. Conf. IEEE Eng. Med. Biol. Soc.*, Sept. 1995; available: CD-ROM
- [8] N. V. Thakor, J. G. Webster, and W. J. Tompkins, "Optimal QRS detector," *Med. Biol. Eng. Comput.*, vol. 21, pp. 343-350, 1983.
- [9] P. P. Vaidyanathan, *Multirate Systems and Filter Banks*. Englewood Cliffs, NJ: Prentice-Hall, 1993.
- [10] G. Strang and T. Q. Nguyen, *Wavelets and Filter Banks*. Wellesley, MA: Wellesley-Cambridge Univ. Press, 1996.
- [11] A. K. Soman, P. P. Vaidyanathan, and T. Q. Nguyen, "Linear phase paraunitary filter banks: Theory, factorizations and designs," *IEEE Trans. Signal Processing*, vol. 41, pp. 3480-3495, Dec. 1993.
- [12] H. S. Malvar, *Signal Processing with Lapped Transforms*. Norwood, MA: Artech House, 1992.
- [13] MIT/BIH Database Distribution, Massachusetts Inst. Technol., Cambridge, MA
- [14] AAMI, Association for the advancement of medical instrumentation, "Recommended practice for testing and reporting performance results of ventricular arrhythmia detection algorithms," 1986.



Valtino X. Afonso (S'91-M'97) received the B.S. degree in electrical and computer engineering from Marquette University, Milwaukee, WI, in 1990 and the M.S. and Ph.D. degrees in electrical and computer engineering from the University of Wisconsin, Madison, in 1993 and 1997, respectively. His research interests include the application of signal processing concepts such as time-frequency analysis, wavelets, multirate processing, filter bank-based algorithms, and classification algorithms to biomedical and image processing solutions.

He is presently working for Endocardial Solutions, Inc. St. Paul, MN. He is a contributing author to *Design of Pacemakers and Implantable Cardioverter-Defibrillators*, J. G. Webster, Ed. (New York, NJ: IEEE Press, 1995) and *Biomedical Digital Signal Processing: C-Language Examples and Laboratory Experiments for the IBM PC*, W. J. Tompkins, Ed. (Englewood Cliffs, NJ: Prentice-Hall, 1993).

Dr. Afonso is a member of Tau Beta Pi.



Willis J. Tompkins (S'61-M'66-SM'77-F'92) received the B.S. and M.S. degrees in electrical engineering from the University of Maine, Orono, in 1963 and 1965, respectively, and the Ph.D. degree in biomedical electronic engineering from the University of Pennsylvania, Philadelphia, in 1973.

From 1965 to 1968, he was an Electrical Engineer at Sanders Associates, Inc., Nashua, NH, where he worked on research and development of data storage systems. He was employed from 1973 to 1974 at the Hospital of the University of Pennsylvania as a Biomedical Engineer. Since 1974, he has been on the faculty of the University of Wisconsin-Madison, Madison. Currently, he is Professor and Chair of the Department of Electrical and Computer Engineering. He teaches undergraduate, graduate, and short courses on the topic of computers in medicine. His research interests include applications of microcomputer-based medical instrumentation and on-line biomedical computing. He is editor of *Biomedical Digital Signal Processing: C Language Examples and Laboratory Experiments for the IBM PC*, (Englewood Cliffs, NJ: Prentice-Hall, 1993). He is coeditor, with J. G. Webster, of *Design of Microcomputer-Based Medical Instrumentation* (Englewood Cliffs, NJ: Prentice-Hall, 1981), and *Interfacing Sensors to the IBM PC* (Englewood Cliffs, NJ: Prentice-Hall, 1988). He is coeditor, with J. G. Webster, A. M. Cook, and G. C. Vanderheiden, of *Electronic Devices for Rehabilitation*, (London, U.K.: Chapman & Hall, 1985).

Dr. Tompkins is a past President of the IEEE Engineering in Medicine and Biology Society. He is also a Member the IEEE Computer Society, the Association for the Advancement of Medical Instrumentation, the Biomedical Engineering Society, and the American Society for Engineering Education. He is a Fellow of the American Institute for Medical and Biological Engineering. He is a Registered Professional Engineer in Wisconsin.

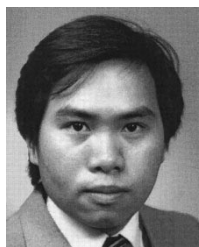

Truong Q. Nguyen (S'85–M'85–SM'95) received the B.S., M.S., and Ph.D. degrees in electrical engineering from the California Institute of Technology, Pasadena, in 1985, 1986, and 1989, respectively.

He was with Massachusetts Institute of Technology (MIT) Lincoln Laboratory from June 1989 to July 1994 as a member of the technical staff. During academic year 1993–1994, he was a visiting Lecturer at MIT and an Adjunct Professor at Northeastern University, Boston, MA. In 1994, he joined the faculty of the Department of Electrical

and Computer Engineering at the University of Wisconsin-Madison, Madison. He is currently Associate Professor of Electrical and Computer Engineering at Boston University, Boston, MA. His research interests are in digital and image signal processing, multirate systems, wavelets and applications, biomedical signal processing, and filter design. He is the co-author, with G. Strang, of *Wavelets and Filter Banks* (Cambridge, MA: Cambridge Wellesley Univ. Press).

Prof. Nguyen was a recipient of a fellowship from Aerojet Dynamics for advanced studies. He received the IEEE TRANSACTIONS ON SIGNAL PROCESSING Paper Award (image and multidimensional processing area) for the paper that he co-wrote with P. P. Vaidyanathan on linear-phase and perfect-reconstruction filter banks. He received the National Science Foundation (NSF) Career Award in 1995. He is currently an Associate Editor for the IEEE TRANSACTIONS ON SIGNAL PROCESSING and also served on the DSP Technical Committee for the CAS Society. He is a member of Tau Beta Pi, Eta Kappa Nu, and Sigma Xi.



Shen Luo (S'92–M'94) received the B.S. and M.S. degrees in electrical engineering from Huazhong University of Science and Technology, Wuhan, China, in 1982 and 1985, respectively, and the Ph.D. degree in electrical engineering from the University of Wisconsin, Madison, in 1994.

He is currently a Research Engineer and Project Leader at Spacelabs Burdick, Inc., Deerfield, WI. He is responsible for the biomedical signal processing and ECG detection algorithms research and product development program. He also manages and

participates as a Researcher in University of Wisconsin-Madison, Madison, research programs which are sponsored by Spacelabs Burdick, Inc. He has published articles in the areas of ECG filtering, ECG detection, noise reduction for bioelectrode measurements, heart rate variability, high-resolution ECG, ECG to vectorcardiogram (VCG) transformation, ECG monitoring, electrode system in impedance-based ventilation monitoring, and detection algorithm for ventilation systems. He is a contributing author of *Prevention of Pressure Sores: Engineering and Clinical Aspects* (Bristol, England: Adam Hilger, 1991), J. G. Webster, Editor.

Dr. Luo is a member of the IEEE Biomedical Engineering Society, the Association for the Advancement of Medical Instrumentation, and the International Society for Computerized Electrocardiology.